

Product Description

Features

- Fully Field-Programmable:
 - I/O functions
 - Digital logic functions
 - Interconnections
- General-purpose array architecture
- Complete user control of design cycle
- Compatible arrays with logic cell complexity equivalent from 600 to 1,500 gates
- Available in 5-V and 3.3-V versions
- 100% factory tested
- Selectable configuration modes
- Low-power, CMOS, static-memory technology
- Performance equivalent to TTL SSI/MSI
- TTL or CMOS input thresholds
- Complete development system support
 - XACT Design Editor
 - Schematic Entry
 - Macro Library
 - Timing Calculator
 - Logic and Timing Simulator
 - Auto Place / Route

Description

The Logic Cell Array (LCA) is a high density CMOS integrated circuit. Its user-programmable array architecture is made up of three types of configurable elements: Input/Output Blocks, logic blocks and Interconnect. The designer can define individual I/O blocks for interface to external circuitry, define logic blocks to implement logic functions and define interconnection networks to compose larger scale logic functions. The XACT Development System provides interactive graphic design capture and automatic routing. Both logic simulation and in-circuit emulation are available for design verification.

The Logic Cell Array is available in a variety of logic capacities, package styles, temperature ranges and speed grades.

Device	V _{CC}	Typ. Logic Capacity (gates)	CLBs	User I/O Max	Config. bits
XC2064	5.0 V	600 – 1,000	64	58	12,038
XC2064L	3.3 V	600 – 1,000	64	58	12,038
XC2018	5.0 V	1,000 - 1,500	100	74	17,878
XC2018L	3.3 V	1,000 - 1,500	100	74	17,878

The XC2000 family operates with a nominal 5.0 V supply. The XC2000L family operates with nominal 3.3 V supply.

The LCA logic functions and interconnections are determined by data stored in internal static-memory cells. On-chip logic provides for automatic loading of configuration data at power-up. The program data can reside in an EEPROM, EPROM or ROM on the circuit board or on a floppy disk or hard disk. The program can be loaded in a number of modes to accommodate various system requirements.

Architecture

The general structure of a Logic Cell Array is shown in Figure 1. The elements of the array include three categories of user programmable elements: I/O Blocks (IOBs), Configurable Logic Blocks (CLBs) and Programmable Interconnections. The IOBs provide an interface between the logic array and the device package pins. The CLBs perform user-specified logic functions, and the interconnect resources are programmed to form networks that carry logic signals among the blocks.

LCA configuration is established through a distributed array of memory cells. The XACT development system generates the program used to configure the Logic Cell Array which includes logic to implement automatic configuration.

Configuration Memory

The configuration of the Logic Cell Array is established by programming memory cells which determine the logic functions and interconnections. The memory loading process is independent of the user logic functions.

The static memory cell used for the configuration memory in the Logic Cell Array has been designed specifically for high reliability and noise immunity. Based on this design, which has been patented, integrity of the LCA configuration memory is assured even under adverse conditions. Compared with other programming alternatives, static memory provides the best combination of high density, high performance, high reliability and comprehensive testability. As shown in Figure 2, the basic memory cell consists of two CMOS inverters plus a pass transistor used for writing data to the cell. The cell is only written during configuration and only read during readback. During normal operation the pass transistor is off and does not affect the stability of the cell. This is quite different from the normal operation of conventional memory devices, in which the cells are continuously read and rewritten.

The outputs Q and \bar{Q} control pass-transistor gates directly. The absence of sense amplifiers and the output capacitive load provide additional stability to the cell. Due to the structure of the configuration memory cells, they are not

affected by extreme power supply excursions or very high levels of alpha particle radiation. In reliability testing no soft errors have been observed, even in the presence of very high doses of alpha radiation.

Input/Output Block

Each user-configurable I/O block (IOB) provides an interface between the external package pin of the device and the internal logic. Each I/O block includes a programmable input path and a programmable output buffer. It also provides input clamping diodes to provide protection from electro-static damage, and circuits to protect the LCA from latch-up due to input currents. Figure 3 shows the general structure of the I/O block.

The input buffer portion of each I/O block provides threshold detection to translate external signals applied to the package pin to internal logic levels. The input buffer threshold of the I/O blocks can be programmed to be compatible with either TTL (1.4 V) or CMOS (2.2 V) levels. The buffered input signal drives both the data input of an

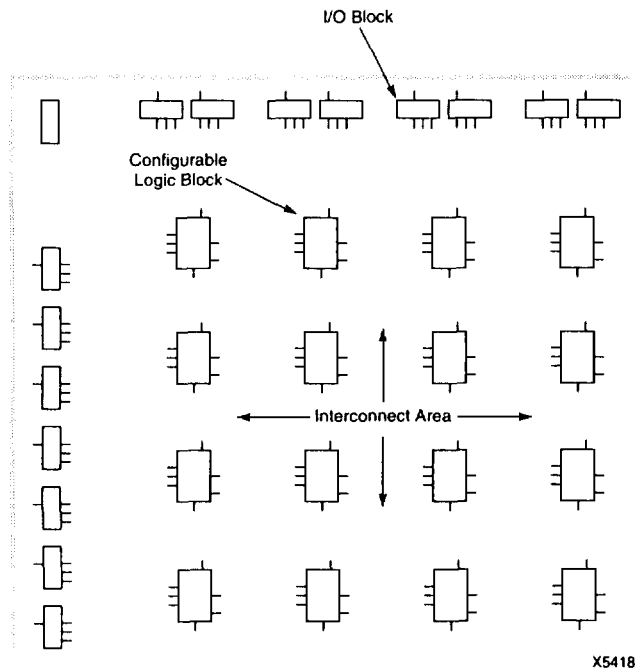
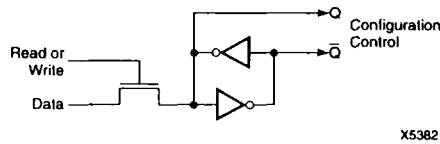

Figure 1. Logic Cell Array Structure



X5382

Figure 2. Configuration Memory Cell

edge-triggered D flip-flop and one input of a two-input multiplexer. The output of the flip-flop provides the other input to the multiplexer. The user can select either the direct input path or the registered input, based on the content of the memory cell controlling the multiplexer. The I/O Blocks along each edge of the die share common clocks. The flip-flops are reset during configuration as well as by the active-low chip RESET input.

Output buffers in the I/O blocks provide 4-mA drive for high fan-out CMOS or TTL-compatible signal levels. The output data (driving I/O block pin O) is the data source for the I/O

block output buffer. Each I/O block output buffer is controlled by the contents of two configuration memory cells which turn the buffer ON or OFF or select 3-state buffer control. The user may also select the output buffer 3-state control (I/O block pin TS). When this I/O block output control signal is High (a logic one), the buffer is disabled and the package pin is high-impedance.

Configurable Logic Block

An array of Configurable Logic Blocks (CLBs) provides the functional elements from which the user's logic is constructed. The logic blocks are arranged in a matrix in the

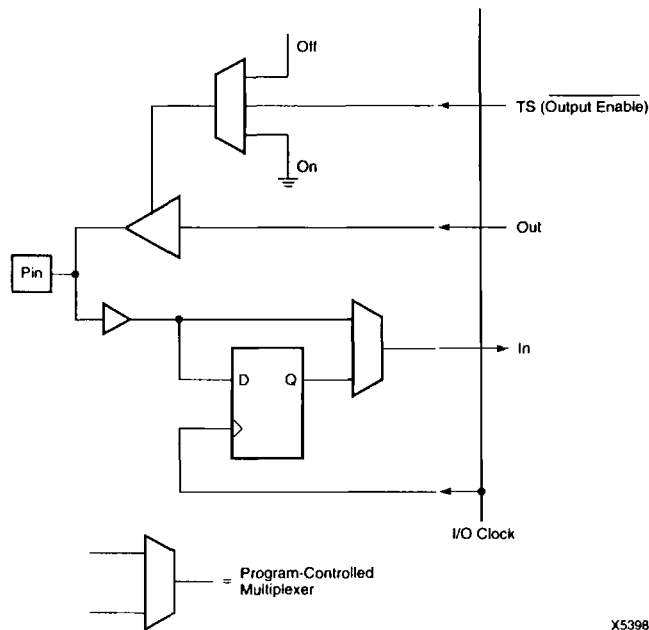

X5398

Figure 3. I/O Block

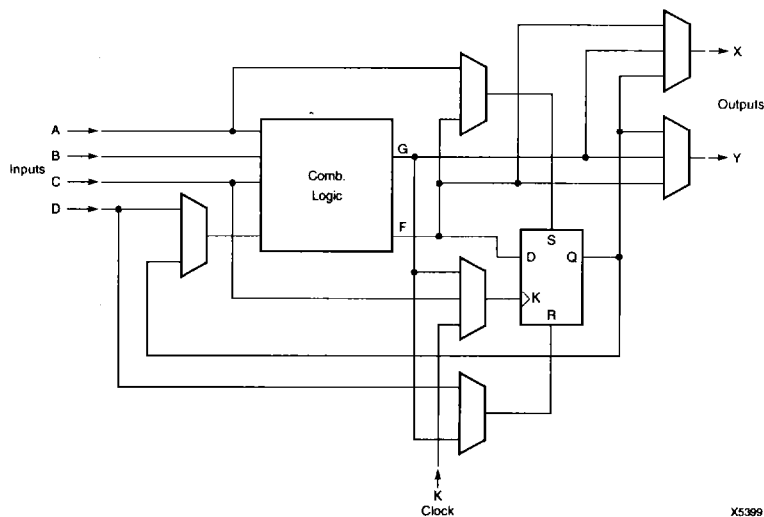

Figure 4. Configurable Logic Block

center of the device. The XC2064 has 64 such blocks arranged in an 8-row by 8-column matrix. The XC2018 has 100 logic blocks arranged in a 10 by 10 matrix.

Each logic block has a combinatorial logic section, a storage element, and an internal routing and control section. Each CLB has four general-purpose inputs: A, B, C and D; and a special clock input (K), which may be driven from the interconnect adjacent to the block. Each CLB also has two outputs, X and Y, which may drive interconnect networks. Figure 4 shows the resources of a Configurable Logic Block.

The logic block combinatorial logic uses a table look-up memory to implement Boolean functions. This technique can generate any logic function of up to four variables with a high speed sixteen-bit memory. The propagation delay through the combinatorial network is independent of the function generated. Each block can perform any function of four variables or any two functions of three variables each. The variables may be selected from among the four inputs and the block's storage element output Q. Figure 5 shows various options which may be specified for the combinatorial logic.

If the single 4-variable configuration is selected (Option 1), the F and G outputs are identical. If the 2-function alternative is selected (Option 2), logic functions F and G may be independent functions of three variables each. The three variables can be selected from among the four logic block inputs and the storage element output Q. A third form of the

combinatorial logic (Option 3) is a special case of the 2-function form in which the B input dynamically selects between the two function tables providing a single merged logic function output. This dynamic selection allows some 5-variable functions to be generated from the four block inputs and storage element Q. Combinatorial functions are restricted in that one may not use both its storage element output Q and the input variable of the logic block pin "D" in the same function.

If used, the storage element in each Configurable Logic Block (Figure 6) can be programmed to be either an edge-sensitive "D" type flip-flop or a level-sensitive "D" latch. The clock or enable for each storage element can be selected from:

- The special-purpose clock input K
- The general-purpose input C
- The combinatorial function G

The user may also select the clock active sense within each logic block. This programmable inversion eliminates the need to route both phases of a clock signal throughout the device.

The storage element data input is supplied from the function F output of the combinatorial logic. Asynchronous SET and RESET controls are provided for each storage element. The user may enable these controls independently and select their source. They are active High inputs and the asynchronous reset is dominant. The

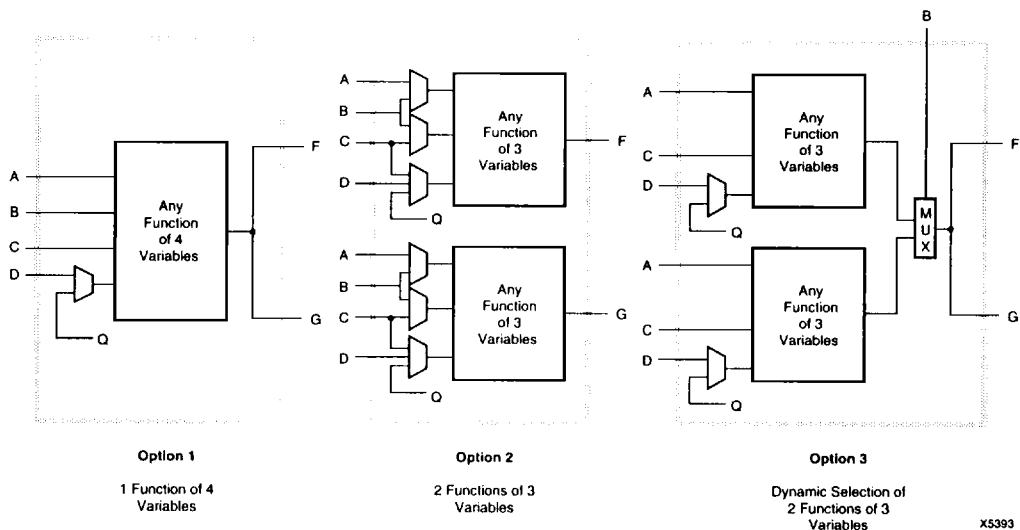

Figure 5. CLB Combinatorial Logic Options

Note: Variables D and Q can not be used in the same function.

storage elements are reset by the active-Low chip RESET pin as well as by the initialization phase preceding configuration. If the storage element is not used, it is disabled.

The two block outputs, X and Y, can be driven by either the combinatorial functions, F or G, or the storage element output Q (Figure 4). Selection of the outputs is completely interchangeable and may be made to optimize routing efficiencies of the networks interconnecting the logic blocks and I/O blocks.

Programmable Interconnect

Programmable interconnection resources in the Logic Cell Array provide routing paths to connect inputs and outputs of the I/O and logic blocks into desired networks. All interconnections are composed of metal segments, with programmable switching points provided to implement the necessary routing. Three types of resources accommodate different types of networks.

- General purpose interconnect
- Longlines
- Direct connection

General-Purpose Interconnect

General-purpose interconnect, as shown in Figure 7a, is composed of four horizontal metal segments between the rows and five vertical metal segments between the columns of logic and I/O blocks. Each segment is only the height or width of a logic block. Where these segments would cross at the intersections of rows and columns,

switching matrices are provided to allow interconnections of metal segments from the adjoining rows and columns. Switches in the switch matrices and on block outputs are specially designed transistors, each controlled by a configuration bit.

Logic-block output switches provide contacts to adjacent general interconnect segments and therefore to the switching matrix at each end of those segments. A switch matrix

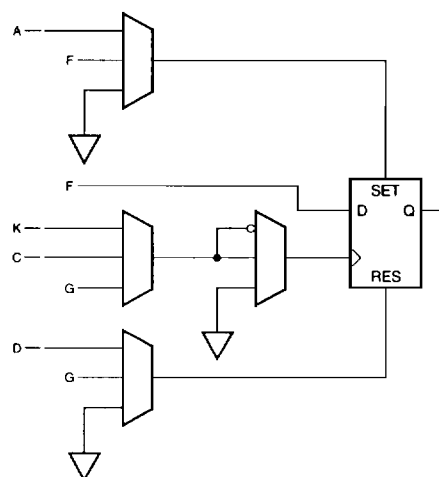
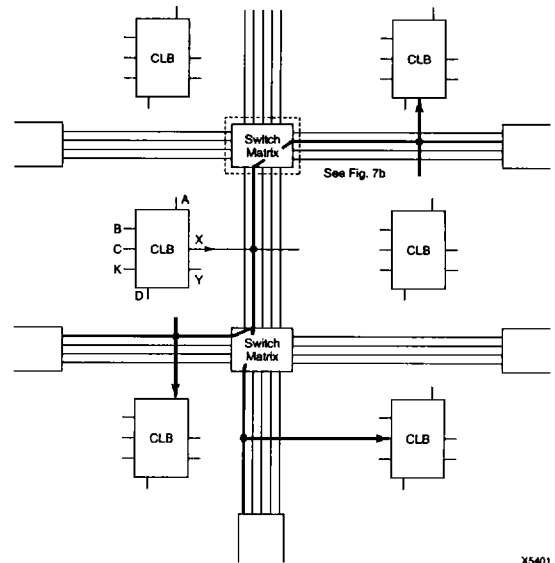

Figure 6. CLB Storage Element

X5400

can connect an interconnect segment to other segments to form a network. Figure 7a shows the general interconnect used to route a signal from one logic block to three other logic blocks. As shown, combinations of closed switches in a switch matrix allow multiple branches for each network. The inputs of the logic or I/O blocks are multiplexers that can be programmed with configuration bits to select an input network from the adjacent interconnect segments. Since the switch connections to block inputs are unidirectional (as are block outputs) they are usable *only* for input connection. The development system software provides automatic routing of these interconnections. Interactive routing is also available for design optimization. This is accomplished by selecting a network and then toggling the states of the interconnect points by selecting them with the "mouse". In this mode, the connections through the switch matrix may be established by selecting pairs of matrix pins. The switching matrix combinations are indicated in Figure 7b.

Special buffers within the interconnect area provide periodic signal isolation and restoration for higher general



X5401

Figure 7a. General-Purpose Interconnect

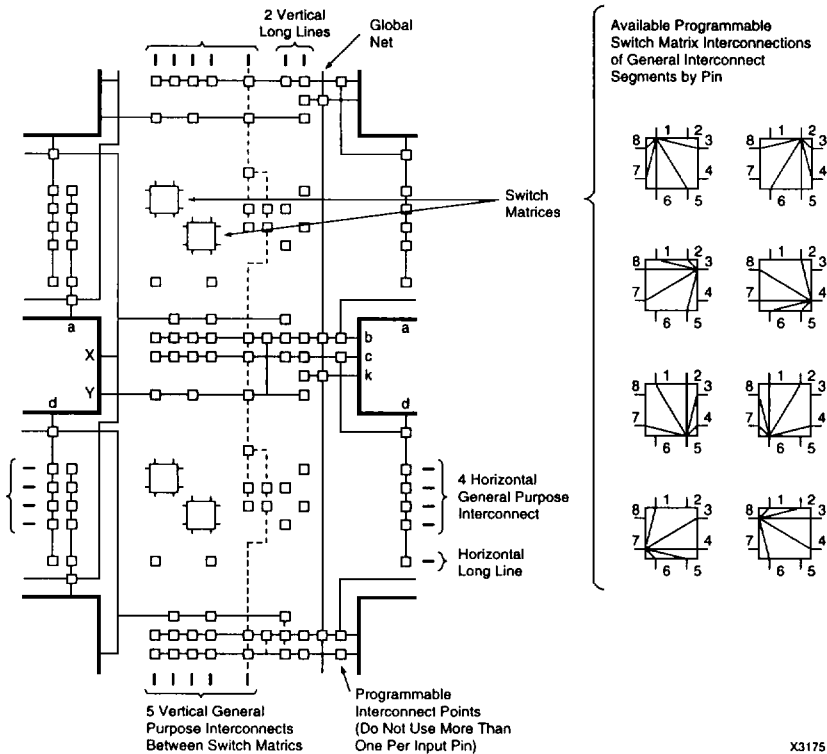

Figure 7b. Routing and Switch Matrix Connections

X3175

interconnect fan-out and better performance. The repowering buffers are bidirectional, since signals must be able to propagate in either direction on a general interconnect segment. Direction controls are automatically established by the Logic Cell Array development system software. Repowering buffers are provided only for the general-purpose interconnect since the direct and Longline resources do not exhibit the same R-C delay accumulation. The Logic Cell Array is divided into nine sections with buffers automatically provided for general interconnect at the boundaries of these sections. These boundaries can be viewed with the development system. For routing within a section, no buffers are used. The delay calculator of the XACT development system automatically calculates and displays the block, interconnect and buffer delays for any selected paths.

Longlines

Longlines, shown in Figure 8a, run both vertically and horizontally the height or width of the interconnect area. Each vertical interconnection column has two Longlines; each horizontal row has one, with an additional Longline adjacent to each set of I/O blocks. The Longlines bypass the switch matrices and are intended primarily for signals

that must travel a long distance or must have minimum skew among multiple destinations.

A global buffer in the Logic Cell Array is available to drive a single signal to all B and K inputs of logic blocks. Using the global buffer for a clock provides a very low skew, high fan-out synchronized clock for use at any or all of the logic blocks. At each block, a configuration bit for the K input to the block can select this global line as the storage element clock signal. Alternatively, other clock sources can be used.

A second buffer below the bottom row of the array drives a horizontal Longline which, in turn, can drive a vertical Longline in each interconnection column. This alternate buffer also has low skew and high fan-out capability. The network formed by this alternate buffer's Longlines can be selected to drive the B, C or K inputs of the logic blocks.

Alternatively, these Longlines can be driven by a logic or I/O block on a column by column basis. This capability provides a common, low-skew clock or control line within each column of logic blocks. Interconnections of these Longlines are shown in Figure 8b.

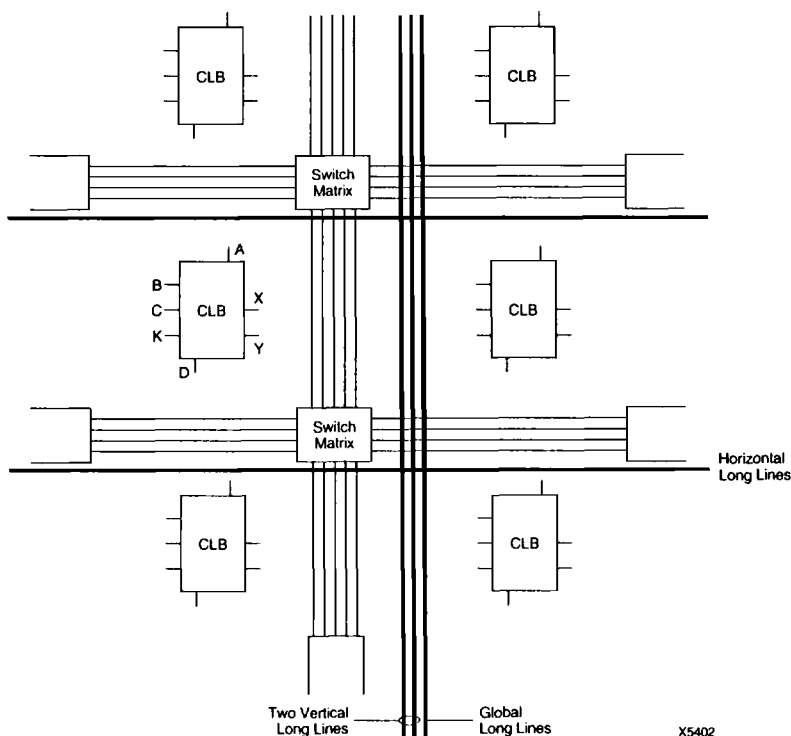

X5402

Figure 8a. Longline Interconnect

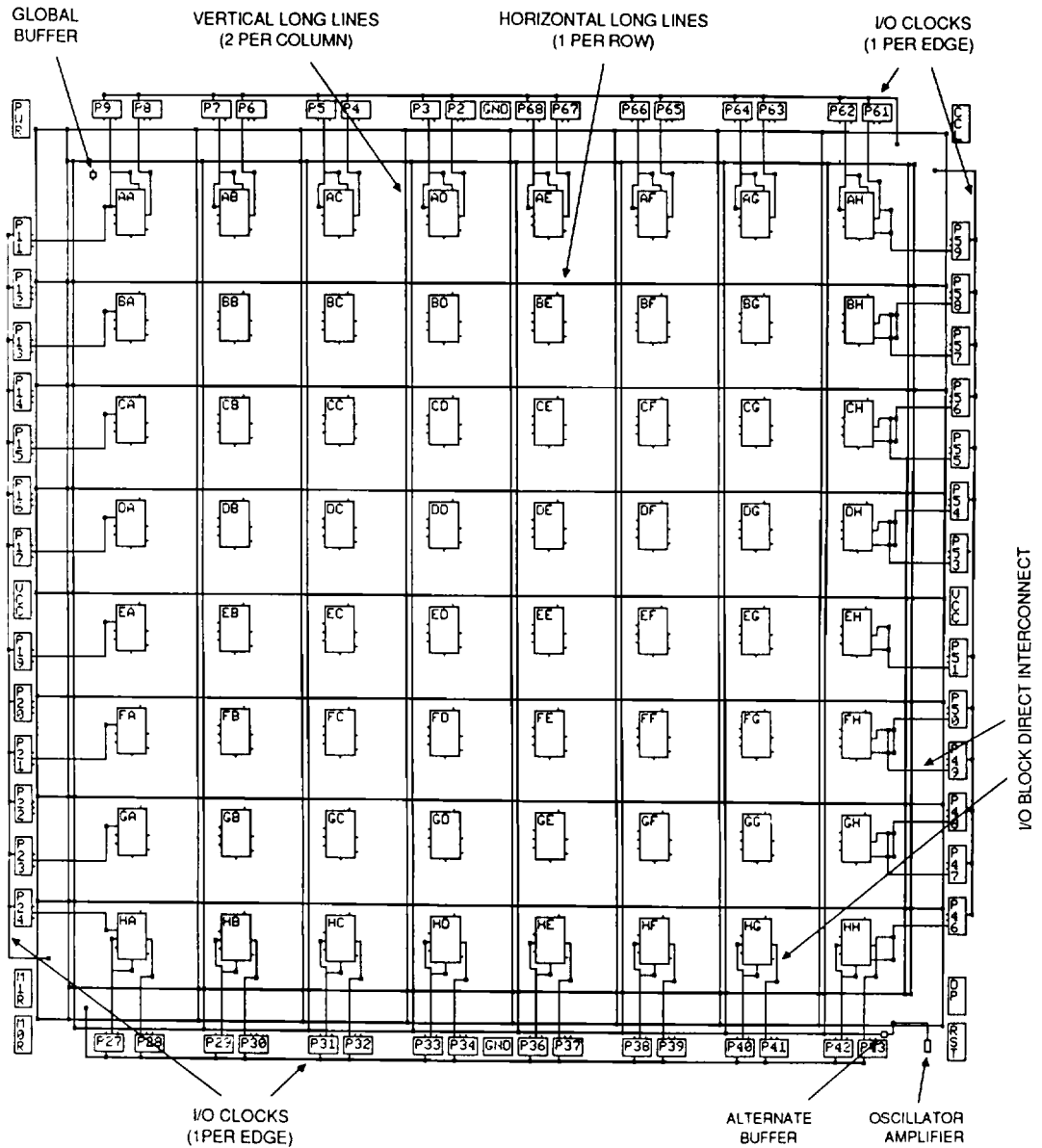

Figure 8b. XC2064 Longlines, I/O Clocks, I/O Direct Interconnect

X1205

Direct Interconnect

Direct interconnect, shown in Figure 9, provides the most efficient implementation of networks between adjacent logic or I/O blocks. Signals routed from block to block by means of direct interconnect exhibit minimum interconnect propagation and use minimum interconnect resources. For each Configurable Logic Block, the X output may be connected directly to the C or D inputs of the CLB above and to the A or B inputs of the CLB below it. The Y output can use direct interconnect to drive the B input of the block immediately to its right. Where logic blocks are adjacent to I/O blocks, direct connect is provided to the I/O block input (I) on the left edge of the die, the output (O) on the right edge, or both on I/O blocks at the top and bottom of the die. Direct interconnections of I/O blocks with CLBs are shown in Figure 8b.

Crystal Oscillator

Figure 8b also shows the location of an internal high speed inverting amplifier which may be used to implement an on-chip crystal oscillator. It is associated with the auxiliary buffer in the lower right corner of the die. When the oscillator is configured by MAKEBITS and connected as a signal source, two special user IOBs are also configured to connect the oscillator amplifier with external crystal oscillator components as shown in Figure 10. The oscillator circuit becomes active early in the configuration process in order to allow the oscillator to stabilize. Actual internal connection is delayed until completion of configuration. In Figure 10, the feedback resistor R1, between the output and input, biases the amplifier at threshold. The inversion of the amplifier, together with the R-C networks and an AT-cut series resonant crystal, produce the 360-degree phase shift of the Pierce oscillator. A series resistor R2 may be included to add to the amplifier output impedance when needed for phase-shift control, crystal resistance matching, or to limit the amplifier input swing to control clipping at large amplitudes. Excess feedback voltage may be corrected by the ratio of C2/C1. The amplifier is designed to be used from 1 MHz to about one-half the specified CLB toggle frequency. Use at frequencies below 1 MHz may require individual characterization with respect to a series resistance. Crystal oscillators above 20 MHz generally require a crystal which operates in a third overtone mode, where the fundamental frequency must be suppressed by an inductor across C2, turning this parallel resonant circuit to double the fundamental crystal frequency, i.e., 2/3 of the desired third harmonic frequency network. When the oscillator inverter is not used, these IOBs and their package pins are available for general user I/O.

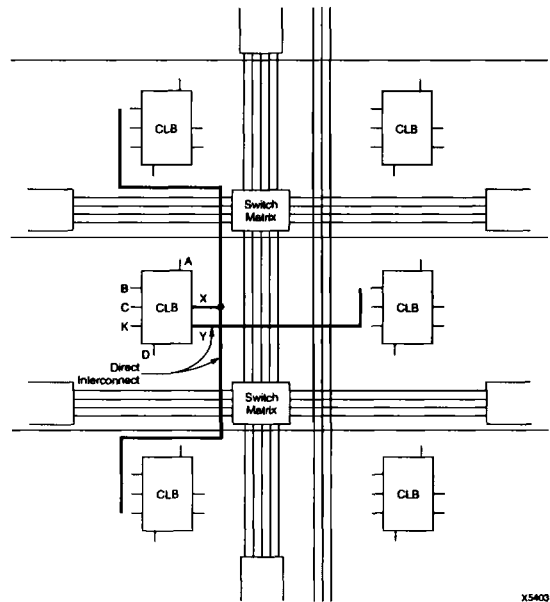
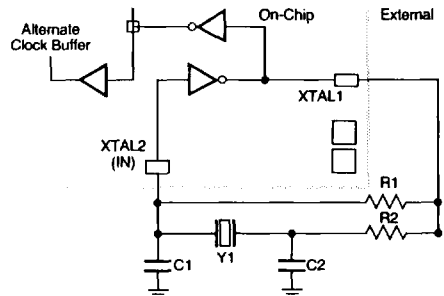

Figure 9. Direct Interconnect



- Suggested Component Values
- R1 0.5 - 1 M Ω
 - R2 0 - 1 k Ω
 - (may be required for low frequency, phase shift and/or compensation level for crystal Q)
 - C1, C2 10 - 40 pF
 - Y1 1 - 20 MHz AT cut series resonant

	XTAL1	XTAL2
48 DIP	33	30
68 PLCC	46	43
68 PGA	J10	L10
84 PLCC	56	53
84 PGA	K11	L11

X5404

Figure 10. Crystal Oscillator

Programming

Table 1. Configuration Mode Selection

M0	M1	M2	CCLK	Mode	Data
0	0	0	output	Master	Bit Serial
0	0	1	output	Master	Byte Wide Addr. = 0000 up
0	1	0	—	reserved	—
0	1	1	output	Master	Byte Wide Addr. = FFFF down
1	0	0	—	reserved	—
1	0	1	output	Peripheral	Bit Serial
1	1	0	—	reserved	—
1	1	1	input	Slave	Bit Serial

Configuration data to define the function and interconnection within a Logic Cell Array are loaded automatically at power-up or upon command. Several methods of automatically loading the required data are designed into the Logic Cell Array and are determined by logic levels applied to mode selection pins at configuration time. The form of the data may be either serial or parallel, depending on the configuration mode. The programming data are independent of the configuration mode selected. The state diagram of Figure 11 illustrates the configuration process. Input thresholds for user I/O pins can be selected to be either TTL-compatible or CMOS-compatible. At power-up, all inputs are TTL-compatible and remain in that state until the LCA begins operation. If the user has selected CMOS compatibility, the input thresholds are changed to CMOS levels during configuration.

Figure 12 shows the specific data arrangement for the XC2064 device. Future products will use the same data format to maintain compatibility between different devices of the Xilinx product line, but they will have different sizes and numbers of data frames. For the XC2064, configuration requires 12,038 bits for each device. For the XC2018, the configuration of each device requires 17,878 bits. The XC2064 uses 160 configuration data frames and the XC2018 uses 197.

The configuration bit stream begins with preamble bits, a preamble code and a length count. The length count is loaded into the control logic of the Logic Cell Array and is used to determine the completion of the configuration process. When configuration is initiated, a 24-bit length counter is set to 0 and begins to count the total number of configuration clock cycles applied to the device. When the current length count equals the loaded length count, the configuration process is complete. Two clocks before completion, the internal logic becomes active and is reset. On the next clock, the inputs and outputs become active as configured and consideration should be given to avoid configuration signal contention. (*Attention must be paid to avoid contention on pins which are used as inputs during configuration and become outputs in operation.*) On the last configuration clock, the completion of configuration is

signalled by the release of the DONE / $\overline{\text{PROG}}$ pin of the device as the device begins operation. This open-drain output can be AND-tied with multiple Logic Cell Arrays and used as an active-High READY or active-Low, $\overline{\text{RESET}}$, to other portions of the system. High during configuration (HDC) and low during configuration (LDC), are released one CCLK cycle before DONE is asserted. In master mode configurations, it is convenient to use $\overline{\text{LDC}}$ as an active-Low EPROM chip enable.

As each data bit is supplied to the LCA, it is internally assembled into a data word. As each data word is completely assembled, it is loaded in parallel into one word of the internal configuration memory array. The last word must be loaded before the current length count compare is true. If the configuration data are in error, e.g., PROM address lines swapped, the LCA will not be ready at the length count and the counter will cycle through an additional complete count prior to configuration being "done".

Table 1 shows the selection of the configuration mode based on the state of the mode pins M0 and M1. These package pins are sampled prior to the start of the configuration process to determine the mode to be used. Once configuration is DONE and subsequent operation has begun, the mode pins may be used to perform data readback, as discussed later. An additional mode pin, M2, must be defined at the start of configuration. This package pin is a user-configurable I/O after configuration is complete.

Initialization Phase

When power is applied, an internal power-on-reset circuit is triggered. When V_{cc} reaches the voltage at which the LCA device begins to operate (nominally 2.5 to 3 V), the chip is initialized, outputs are made high-impedance and a time-out is initiated to allow time for power to stabilize. This time-out (11 to 33 ms) is determined by a counter driven by a self-generated, internal sampling clock that drives the configuration clock (CCLK) in master configuration mode. This internal sampling clock will vary with process, temperature and power supply over the range of 0.5 to 1.5 MHz. LCA devices with mode lines set for master mode will time-out of their initialization using a longer counter (43 to 130 ms) to assure that all devices, which it may be driving in a daisy chain, will be ready. Configuration using peripheral or slave modes must be delayed long enough for this initialization to be completed.

The initialization phase may be extended by asserting the active-Low external $\overline{\text{RESET}}$. If a configuration has begun, an assertion of $\overline{\text{RESET}}$ will initiate an abort, including an orderly clearing of partially loaded configuration memory bits. After about three clock cycles for synchronization, initialization will require about 160 additional cycles of the internal sampling clock (197 for the XC2018) to clear the internal memory before another configuration may begin.

Power-On Delay is
 2^{14} Cycles for Non-Master Mode—11 to 33 ms
 2^{16} Cycles for Master Mode—43 to 130 ms

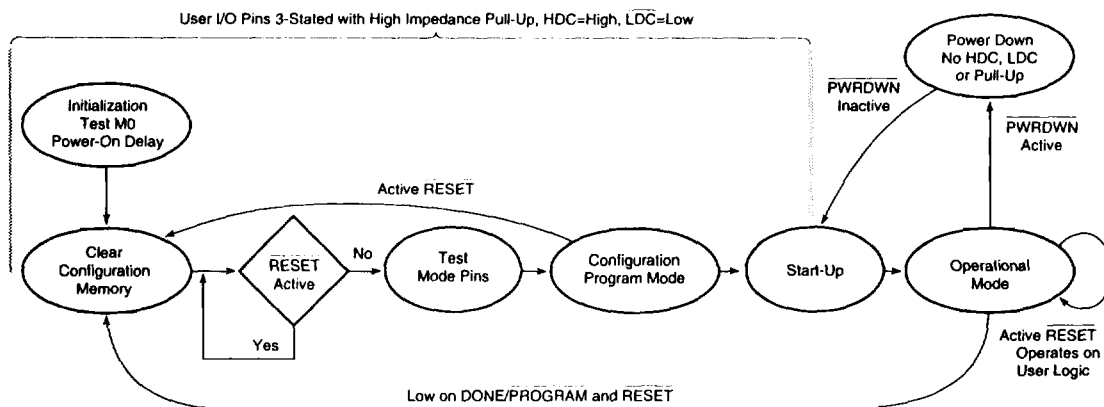

Clear Is
 - 160 Cycles for the XC2064—100 to 320 μ s
 - 200 Cycles for the XC2018—125 to 390 μ s

X5307

Figure 11. A State Diagram of the Configuration Process for Power-up and Reprogram

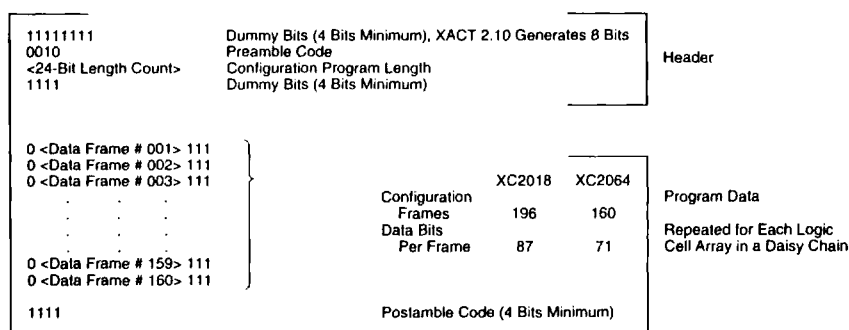

Start-Up Requires Three Configuration Clocks Beyond Length Count

X5405

Figure 12. XC2064 Internal Configuration Data Arrangement

Reprogramming is initialized by a High-to-Low transition on RESET (after RESET has been High for at least 6 μ s) followed by a Low level (for at least 6 μ s) on both the RESET and the open-drain DONE/PROG pins. This returns the LCA device to the CLEAR state, as shown in Figure 11.

Master Mode

In Master mode, the Logic Cell Array automatically loads the configuration program from an external memory device. The Master Serial mode uses serial configuration data, synchronized by the rising edge of CCLK, as shown in Figure 13.

In Master Parallel mode (Figure 14), the Logic Cell Array provides 16 address outputs and the control signals RCLK (Read Clock), HDC (High during configuration) and LDC (Low during configuration) to execute Read cycles from the external memory. Parallel 8-bit data words are read and internally serialized. As each data word is read, the least significant bit of each byte, normally D0, is the next bit in the serial stream.

Addresses supplied by the Logic Cell Array can be selected by the mode lines to begin at address 0 and incremented to reach the memory (master Low mode), or they can begin at address FFFF Hex and be decremented

(master High mode). This capability is provided to allow the Logic Cell Array to share external memory with another device, such as a microprocessor. For example, if the processor begins its execution from Low memory, the Logic Cell Array can load itself from High memory and enable the processor to begin execution once configuration is completed. The Done/PROG output pin can be used to hold the processor in a Reset state until the Logic Cell Array has completed the configuration process

Peripheral Mode (Bit Serial)

Peripheral mode provides a simplified interface through which the device may be loaded as a processor peripheral. Figure 15 shows the peripheral mode connections. Processor Write cycles are decoded from the common assertion of the active-Low write strobe (IOWRT), and two active-Low and of the active-High chip selects (CS0 CS1 CS2). If all these signals are not available, the unused inputs should be driven to their respective active levels. The Logic Cell Array will accept one bit of the configuration program on the data input (DIN) pin for each processor Write cycle. Data is supplied in the serial sequence described earlier.

Since only a single bit from the processor data bus is loaded per cycle, the loading process involves the processor reading a byte or word of data, writing a bit of the data to the Logic cell Array, shifting the word and writing a bit until all bits of the word are written, then continuing in the same fashion with the next word, etc. After the configuration program has been loaded, an additional three clocks (a total of three more than the length count) must be supplied in order to complete the configuration process. When more than one device is being used in the system, each device can be assigned a different bit in the processor data bus, and multiple devices can be loaded on each processor write cycle. This broadside loading method provides a very easy and time-efficient method of loading several devices.

Slave Mode

Slave mode, Figure 16, provides the simplest interface for loading the Logic Cell Array configuration. Data is supplied in conjunction with a synchronizing clock. For each Low-to-High input transition of configuration clock (CCLK), the data present on the data input (DIN) pin is loaded into the internal shift register. Data may be supplied by a processor or by other special circuits. Slave mode is used for downstream devices in a daisy-chain configuration. The data for each slave LCA device are supplied by the preceding LCA device in the chain, and the clock is supplied by the lead device, which is configured in master or peripheral mode. After the configuration program has been loaded, an additional three clocks (a total of three more than the length count) must be supplied in order to complete the configuration process.

Daisy Chain

The daisy-chain programming mode is supported by Logic Cell Arrays in all programming modes. In master mode and peripheral modes, the LCA device can act as a source of data and control for slave devices. For example, Figure 14 shows a single device in master mode, with two devices in slave mode. The master-mode device reads the external memory and begins the configuration loading process for all of the devices.

The data begins with a preamble and a length count which are supplied to all devices at the beginning of the configuration. The length count represents the total number of cycles required to load all of the devices in the daisy chain. After loading the length count, the lead device will load its configuration data while providing a High DOUT to downstream devices. When the lead device has been loaded and the current length count has not reached the full value, memory access continues. Data bytes are read and serialized by the lead device. The data is passed through the lead device and appears on the data out (DOUT) pin in serial form. The lead device also generates the configuration clock (CCLK) to synchronize the serial output data. A master-mode device generates an internal CCLK of eight times the EPROM address rate, while a peripheral mode device produces CCLK from the chip select and write strobe timing.

Operation

When all of the devices have been loaded and the length count is complete, a synchronous start-up of operation is performed. On the clock cycle following the end of loading, the internal logic begins functioning in the reset state. On the next CCLK, the configured output buffers become active to allow signals to stabilize. The next CCLK cycle produces the DONE condition. The length count control of operation allows a system of multiple Logic Cell Arrays to begin operation in a synchronized fashion. If the crystal oscillator is used, it will begin operation before configuration is complete to allow time for stabilization before it is connected to the internal circuitry.

Reprogram

The Logic Cell Array configuration memory may be rewritten while the device is operating in the user's system. The LCA device returns to the Clear state where the configuration memory is cleared, I/O pins disabled, and mode lines re-sampled. Reprogram control is often implemented using an external open collector driver which pulls DONE/PROG LOW. Once it recognizes a stable request, the Logic Cell Array holds DONE/PROG LOW until the new configuration has been completed. Even if the DONE/PROG pin is externally held LOW beyond the configuration period, the Logic Cell Array begins operation upon completion of configuration. To reduce sensitivity to noise, these re-program signals are filtered for 2-3 cycles of the

LCA internal timing generator (2 to 6 μ s). Note that the Clear time-out for a master-mode reprogram or abort does not have the 4 times delay of the Initialization state. If a daisy chain is used, an external $\overline{\text{RESET}}$ is required, long enough to guarantee clearing all non-master mode devices. For XC2000-series LCA devices, this is accomplished with an external time delay.

In some applications the system power supply might have momentary failures which can leave the LCA control logic in an invalid state. There are two methods to recover from this state. The first is to cycle the V_{CC} supply to less than 0.1 V and re-apply valid V_{CC} . The second is to provide the LCA device with simultaneous Low levels of at least 6 μ s on $\overline{\text{RESET}}$ and DONE/PROG pins after the $\overline{\text{RESET}}$ pin has been High following a return to valid V_{CC} . This guarantees that the LCA device will return to the Clear state. Either of these methods may be needed in the event of an incomplete voltage interruption. They are not needed for a normal application of power from an off condition.

Battery Backup

Because the control store of the Logic Cell Array is a CMOS static memory, its cells require only a very low standby current for data retention. In some systems, this low data-retention current characteristic facilitates preserving configurations in the event of a primary power loss. The Logic Cell Array has built in power-down logic which, when activated, clears all internal flip-flops and latches, but retains the configuration. All outputs are placed in the high-impedance state, and all input levels are ignored. The internal logic considers all inputs to be ones (High). Configuration is not possible during power down.

Power-down data retention is possible with a simple battery-backup circuit because the power requirement is extremely low. For retention at 2.0 V, the required current is typically on the order of 500 nA. Screening to this parameter is available. To force the Logic Cell Array into the power-down state, the user must pull the $\overline{\text{PWRDWN}}$ pin Low and continue to supply a retention voltage to the V_{CC} pins of the package. When normal power is restored, V_{CC} is elevated to its normal operating voltage and $\overline{\text{PWRDWN}}$ is returned to a High. The Logic Cell Array resumes operation with the same internal sequence that occurs at the conclusion of configuration. Internal I/O and logic block storage elements will be reset, the outputs will become enabled and then the DONE/PROG pin will be released. No configuration programming is involved.

Special Configuration Functions

In addition to the normal user logic functions and interconnect, the configuration data include control for several special functions:

- Input thresholds
- Readback disable
- DONE pull-up resistor

Each of these functions is controlled by a portion of the configuration program generated by the XACT Development System.

Input Thresholds

During configuration, all input thresholds are TTL level. After configuration, input thresholds are established as specified, either TTL or CMOS. The $\overline{\text{PWRDWN}}$ input threshold is an exception; it is always a CMOS level input. The TTL threshold option requires additional power for threshold shifting.

Readback

After a Logic Cell Array has been programmed, the configuration program may be read back from the device. Readback may be used for verification of configuration, and as a method of determining the state of internal logic nodes during debugging. Three Readback options are provided: on command, only once, and never.

An initiation of Readback is produced by a Low-to-High transition of the $\text{M0}/\text{RTRIG}$ (Read Trigger) pin. The CCLK input must then be driven by external logic to read back the configuration data. The first three Low-to-High CCLK transitions clock out dummy data. The subsequent Low-to-High CCLK transitions shift the data frame information out on the $\text{M1}/\text{RDATA}$ (Read Data) pin. Note that the logic polarity is always inverted, a zero in Configuration becomes a one in Readback, and vice versa. Note also that each Readback frame has one Start bit (read back as a one) but, unlike in Configuration, each Readback frame has only one Stop bit (read back as a zero). The third leading dummy bit mentioned above can be considered the Start bit of the first frame.

All data frames must be read back to complete the process and return the Mode Select and CCLK pins to their normal functions. Readback data includes the state of all internal storage elements. This information is used by the XACT development system In-Circuit Debugger to provide visibility into the internal operation of the logic while the system is operating. To read back a uniform time sample of all storage elements, it may be necessary to inhibit the system clock.

DONE Pull-up

The DONE/PROG pin is an open drain I/O that indicates programming status. As an input, it initiates a reprogram operation. An optional internal pull-up resistor may be enabled.

The following seven pages describe the four configuration modes in detail.

Master Serial Mode

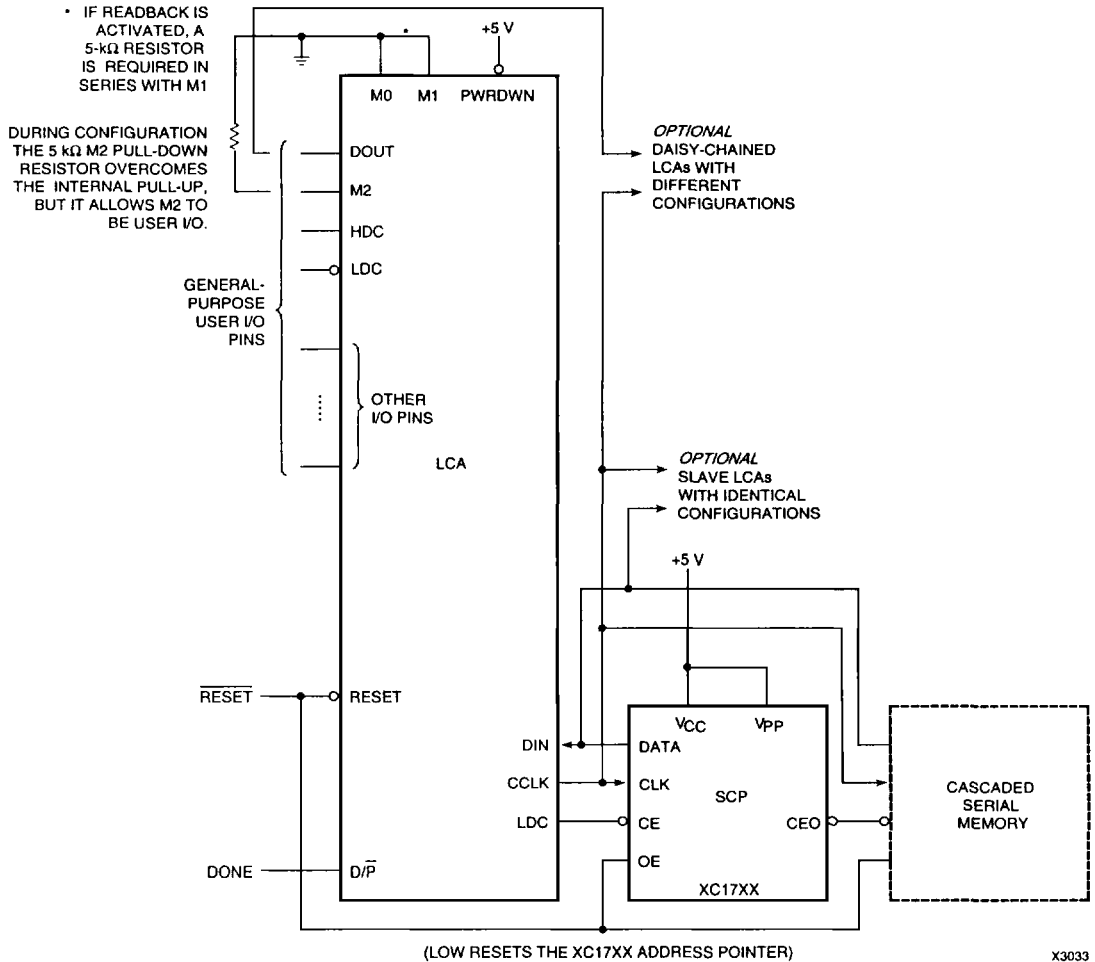

Figure 13. Master Serial Mode

In Master Serial mode, the CCLK output of the lead LCA device drives a Xilinx Serial PROM that feeds the LCA DIN input. Each rising edge of the CCLK output increments the Serial PROM internal address counter. This puts the next data bit on the SPROM data output, connected to the LCA DIN pin. The lead LCA device accepts this data on the subsequent rising CCLK edge.

The lead LCA device then presents the preamble data (and all data that overflows the lead device) on its DOUT pin.

There is an internal delay of 1.5 CCLK periods, which means that DOUT changes on the falling CCLK edge, and the next LCA device in the daisy-chain accepts data on the subsequent rising CCLK edge.

The SPROM CE input can be driven from either \overline{LDC} or DONE. Using \overline{LDC} avoids potential contention on the DIN pin, if this pin is configured as user-I/O, but \overline{LDC} is then restricted to be a permanently High user output. Using DONE also avoids contention on DIN, provided the "early DONE" option is invoked

Master Serial Mode Programming Switching Characteristics

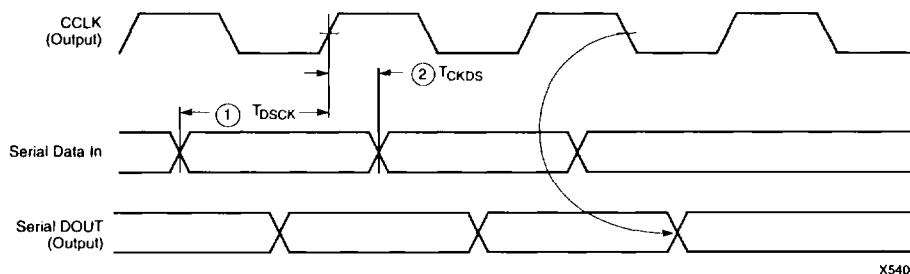

X5406

		Speed Grade		-50		-70		-100		Units
		Description	Symbol	Min	Max	Min	Max	Min	Max	
CCLK ²	1	Data In setup	T_{DSCK}	60		60		60		ns
	2	Data In hold	T_{CKDS}	0		0		0		ns

Notes: 1. At power-up, V_{CC} must rise from 2.0 V to V_{CC} min in less than 25 ms. If this is not possible, configuration can be delayed by holding RESET Low until V_{CC} has reached 4.0 V (2.5 V for XC2000L). A very long V_{CC} rise time of >100 ms, or a non-monotonically rising V_{CC} may require a >1- μ s High level on RESET, followed by a >6- μ s Low level on RESET and D/P after V_{CC} has reached 4.0 V (2.5 V for XC2000L).

2. Master-serial-mode timing is based on slave-mode testing.

Master Parallel Mode

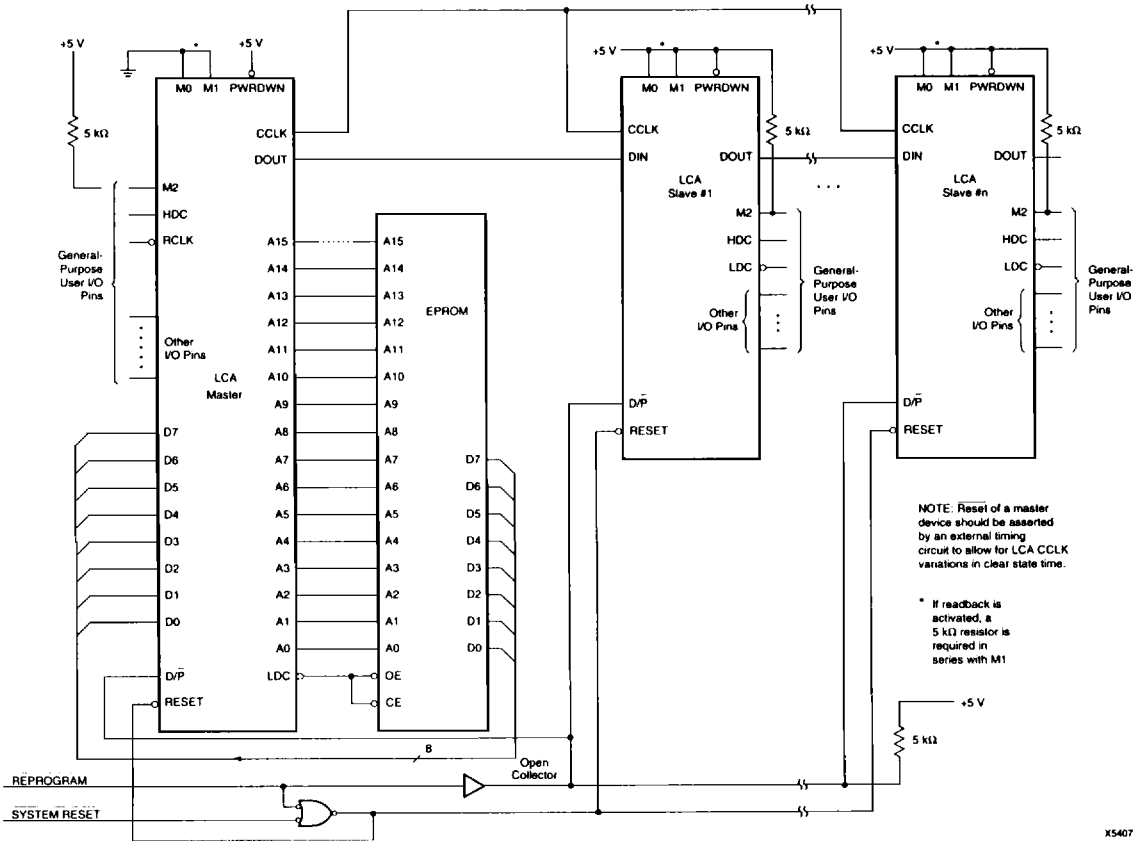

Figure 14. Master Parallel Mode Configuration with Daisy Chained Slave Mode Devices. All are configured from the common EPROM source. A well defined termination of SYSTEM RESET is needed when controlling multiple LCA devices.

In Master Parallel mode, the lead LCA device directly addresses an industry-standard byte-wide EPROM and accepts eight data bits right before incrementing (or decrementing) the address outputs.

The eight data bits are serialized in the lead LCA device, which then presents the preamble data (and all data that overflows the lead device) on the DOUT pin. There is an internal delay of 1.5 CCLK periods, after the rising CCLK edge that accepts a byte of data, and also changes the

EPROM address, until the falling CCLK edge that makes the LSB (D0) of this byte appear at DOUT. This means that DOUT changes on the falling CCLK edge, and the next LCA device in the daisy-chain accepts data on the subsequent rising CCLK edge.

Any XC3000 slave driven by an XC2000 master mode device must use early DONE and early internal reset. (The XC2000 master will not supply the extra clock required by a late programmed XC3000.)

Master Parallel Mode Programming Switching Characteristics

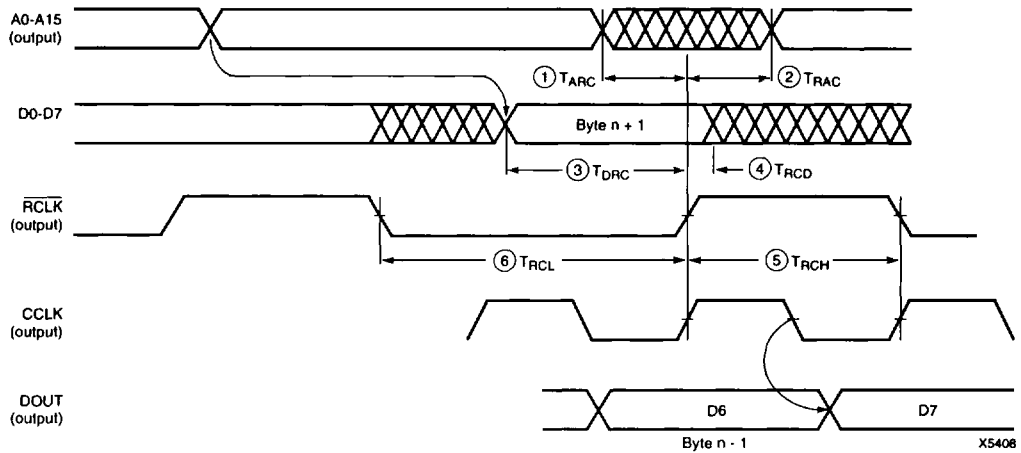

	Description	Symbol	Min	Max	Units
RCLK	From address invalid	1 T_{ARC}		0	ns
	To address valid	2 T_{RAC}		200	ns
	To data setup	3 T_{DRC}	60		ns
	To data hold	4 T_{RCD}	0		ns
	RCLK high	5 T_{RCH}	600		ns
	RCLK low	6 T_{RCL}	4.0		μ s

Note: 1. CCLK and DOUT timing are the same as for slave mode.

2. At power-up, V_{CC} must rise from 2.0 V to V_{CC} min in less than 25 ms. If this is not possible, configuration can be delayed by holding RESET Low until V_{CC} has reached 4.0 V (2.5 V for XC2000L). A very long V_{CC} rise time of >100 ms, or a non-monotonically rising V_{CC} may require a >1- μ s High level on RESET, followed by a >6- μ s Low level on RESET and D/P after V_{CC} has reached 4.0 V (2.5 V for XC2000L).

This timing diagram shows that the EPROM requirements are extremely relaxed: EPROM access time can be longer than 4000 ns, EPROM data output has no hold time requirement

Peripheral Mode

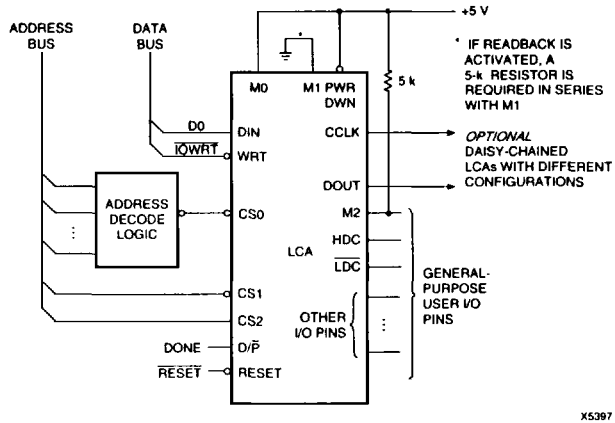
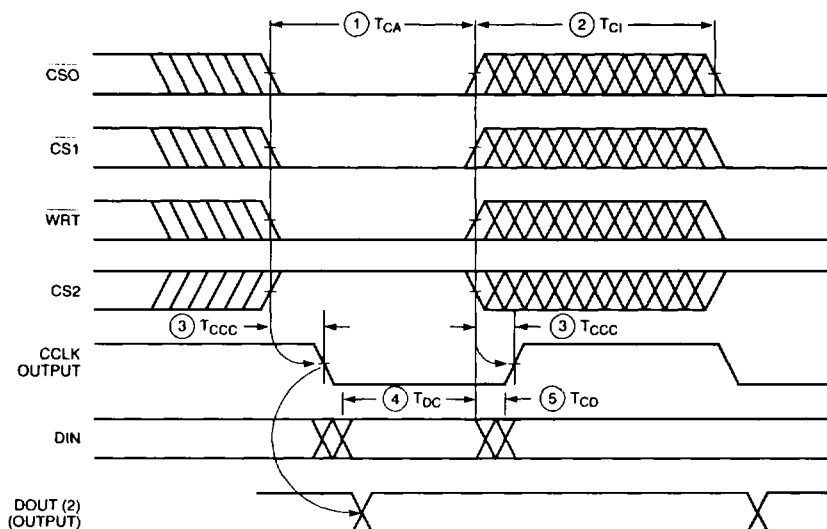

Figure 15. Peripheral Mode. Configuration data is loaded using serialized data from a microprocessor.

Peripheral mode uses the trailing edge of the logic AND condition of the CS0, CS1, CS2, and WRT inputs to accept bit-serial data from a microprocessor bus. In the lead LCA

device, this data is serially shifted into the internal logic. The lead LCA device presents the preamble data (and all data that overflows the lead device) on the DOUT pin.

Peripheral Mode Programming Switching Characteristics



X5384

	Description	Symbol	Min	Max	Units
Controls ¹ (CS0, CS1, CS2, WRT)	Active (last active input to first inactive)	1 T _{CA}	0.25	5.0	μs
	Inactive (first inactive input to last active)	2 T _{CI}	0.25		μs
CCLK ² DIN setup DIN hold	CCLK ²	3 T _{CCC}		75	ns
	DIN setup	4 T _{DC}	50		ns
	DIN hold	5 T _{CD}	0		ns

- Notes:
- Peripheral mode timing determined from last control signal of the logical AND of (CS0, CS1, CS2, WRT) to transition to active or inactive state.
 - CCLK and DOUT timing are the same as for slave mode.
 - At power-up, V_{CC} must rise from 2.0 V to V_{CC} min in less than 25 ms. If this is not possible, configuration can be delayed by holding RESET Low until V_{CC} has reached 4.0 V (2.5 V for XC2000L). A very long V_{CC} rise time of >100 ms, or a non-monotonically rising V_{CC} may require a >1-μs High level on RESET, followed by a >6-μs Low level on RESET and D/P after V_{CC} has reached 4.0 V (2.5 V for XC2000L).

Slave Serial Mode

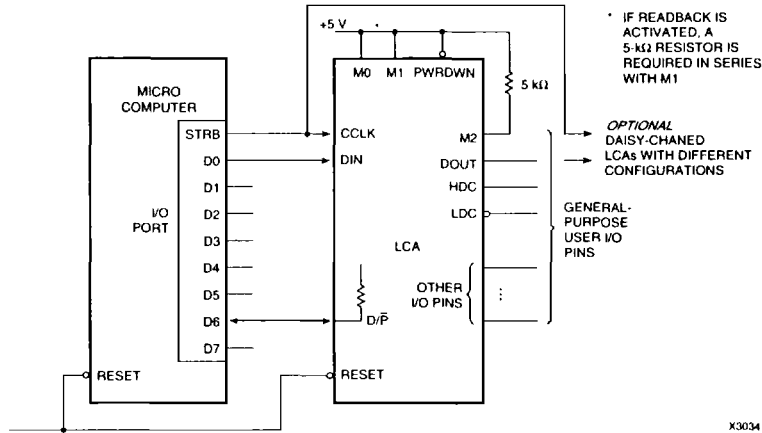

X3034

Figure 16. Slave Serial Mode. Bit-serial configuration data are read at rising edge of the CCLK. Data on DOUT are provided on the falling edge of CCLK. Identically configured non-master mode LCAs can be configured in parallel by connecting DINs and CCLKs.

In Slave Serial mode, an external signal drives the CCLK input(s) of the LCA device(s). The serial configuration bitstream must be available at the lead LCA device a short set-up time before each rising CCLK edge. The lead LCA device then presents the preamble data (and all data that overflows the lead device) on its DOUT pin.

There is an internal delay of 1.5 CCLK periods, which means that DOUT changes on the falling CCLK edge, and the next LCA device in the daisy-chain accepts data on the subsequent rising CCLK edge.

Slave Serial Mode Programming Switching Characteristics

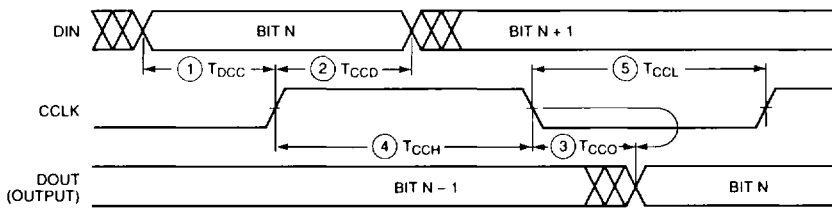

X5385

Description		Symbol	Min	Max	Unit
CCLK	To DOUT	1 T_{CCO}		65	ns
	DIN setup	2 T_{DCC}	10		ns
	DIN hold	3 T_{CCD}	40		ns
	High time	4 T_{CCH}	0.25		μ s
	Low time	5 T_{CCL}	0.25	5.0	μ s
	Frequency	F_{CC}		2	MHz

Note: At power-up, V_{CC} must rise from 2.0 V to V_{CC} min in less than 25 ms. If this is not possible, configuration can be delayed by holding RESET Low until V_{CC} has reached (2.5 V for the XC2000L). A very long V_{CC} rise time of >100 ms, or a non-monotonically rising V_{CC} may require a >1- μ s High level on RESET, followed by a >6- μ s Low level on RESET and D/P after V_{CC} has reached (2.5 V for the XC2000L).

Program Readback Switching Characteristics

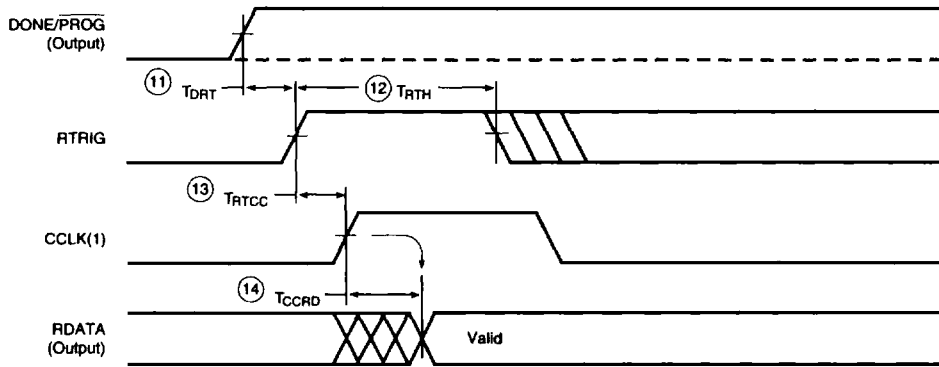

X3168

Description		Symbol		Min	Max	Units
RTRIG	PROG setup	11	T_{DRT}	300		ns
	RTRIG high	12	T_{RTH}	250		ns
CCLK	RTRIG setup	13	T_{RTCC}	100		ns
	RDATA delay	14	T_{CCRD}		100	ns

Notes: 1. CCLK and DOUT timing are the same as for slave mode, but T_{CCL} for XC2000L is 0.5 μ s min.

2. DONE/PROG output/input must be HIGH (device programmed) prior to a positive transition of RTRIG (M0).

General LCA Switching Characteristics

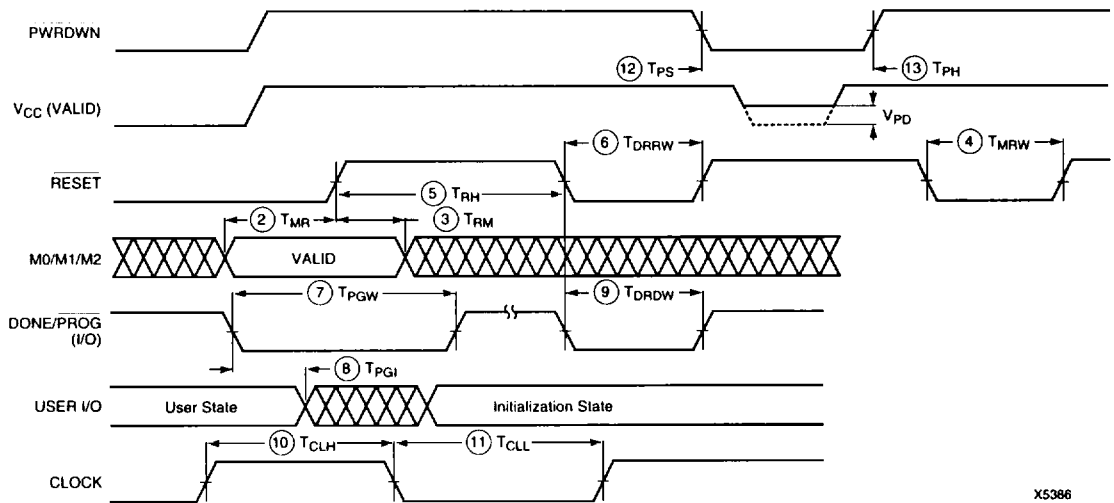

X5386

Description		Symbol	Min	Max	Units
RESET ²	M2, M1, M0 setup	2 T _{MR}	60		ns
	M2, M1, M0 hold	3 T _{RM}	60		ns
	Width—FF Reset	4 T _{MRW}	150		ns
	High before RESET ⁴	5 T _{RH}	6		μs
	Device Reset ⁴	6 T _{DRRW}	6		μs
DONE/PROG	Program width (Low)	7 T _{PGW}	6		μs
	Initialization	8 T _{PGI}		7	μs
	Device Reset ⁴	9 T _{DRDW}	6		μs
CLOCK	Clock (High)	10 T _{CLH}	8		ns
	Clock (Low)	11 T _{CLL}	8		ns

- Notes:
- At power-up, V_{CC} must rise from 2.0 V to V_{CC} min in less than 25 ms. If this is not possible, configuration can be delayed by holding RESET Low until V_{CC} has reached (2.5 V for the XC2000L). A very long V_{CC} rise time of >100 ms, or a non-monotonically rising V_{CC} may require a >1-μs High level on RESET, followed by a >6-μs Low level on RESET and D/P after V_{CC} has reached (2.5 V for the XC2000L).
 - RESET timing relative to power-on and valid mode lines (M0, M1, M2) is relevant only when RESET is used to delay configuration.
 - Minimum CLOCK widths for the auxiliary buffer are 1.25 times the T_{CLH}, T_{CLL}.
 - After RESET is High, RESET = D/P = Low for 6 μs will abort to CLEAR.

Performance

The high performance of the Logic Cell Array results from its patented architectural features and from the use of an advanced high-speed CMOS manufacturing process. Performance may be measured in terms of minimum propagation times for logic elements.

Flip-flop loop delays for the I/O block and logic block flip-flops are about 3 ns. This short delay provides very good performance under asynchronous clock and data conditions. Short loop delays minimize the probability of a metastable condition which can result from assertion of the clock during data transitions. Because of the short loop delay characteristic in the LCA device, the I/O block flip-flops can be used very effectively to synchronize external signals applied to the device. Once synchronized in the I/O block, the signals can be used internally without further consideration of their clock relative timing, except as it applies to the internal logic and routing path delays.

Device Performance

The single parameter which most accurately describes the overall performance of the Logic Cell Array is the maximum toggle rate for a logic block storage element configured as a toggle flip-flop. The configuration for determining the toggle performance of the Logic Cell Array is shown in Figure 17. The clock for the storage element is provided by the global clock buffer and the flip-flop output Q is fed back through the combinatorial logic to form the data input for the next clock edge. Using this arrangement, flip-flops in the Logic Cell Array can be toggled at clock rates from 33–100 MHz, depending on the speed grade used.

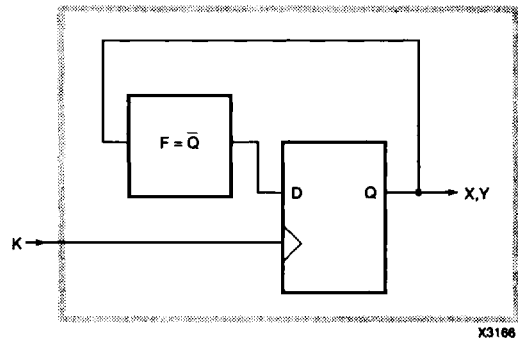

Figure 17. Logic Block Configuration for Toggle Rate Measurement

Actual Logic Cell Array performance is determined by the critical path speed, including both the speed of the logic and storage elements in that path, and the speed of the particular network routing. Figure 18 shows a typical system logic configuration of two flip-flops with an extra combinatorial level between them. To allow the user to make the best use of the capabilities of the device, the delay calculator in the XACT Development System determines worst-case path delays using actual impedance and loading information.

Logic Block Performance

Logic block propagation times are measured from the interconnect point at the input of the combinatorial logic to the output of the block in the interconnect area. Combinatorial performance is independent of logic function

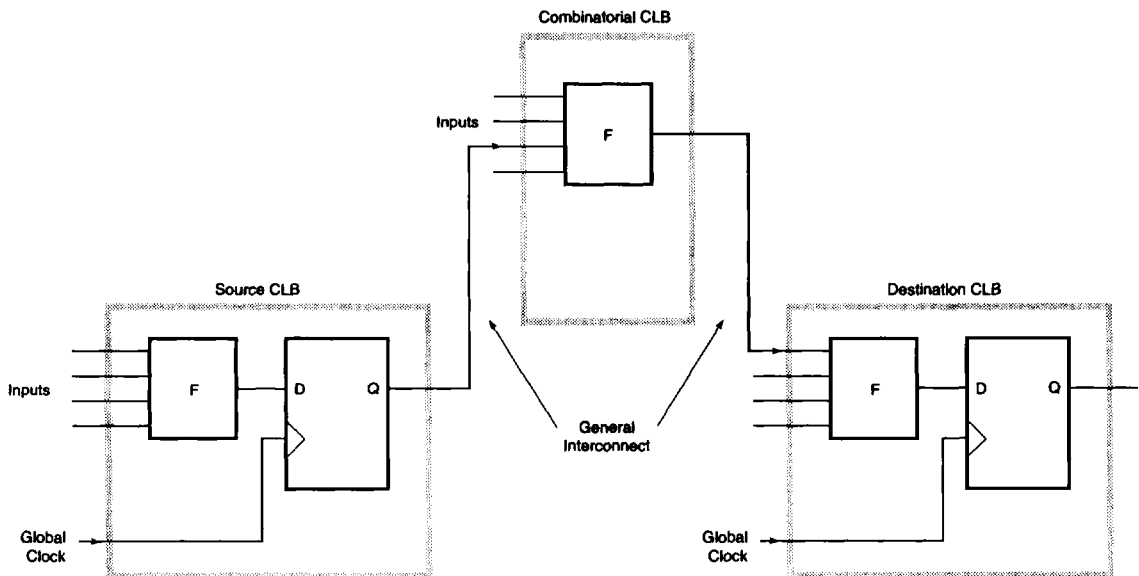

Figure 18. Typical Logic Path

X3167

because of the table look-up based implementation. Timing is different when the combinatorial logic is used in conjunction with the storage element. For the combinatorial logic function driving the data input of the storage element, the critical timing is data set-up relative to the clock edge provided to the storage element. The delay from the clock source to the output of the logic block is critical in the timing of signals produced by storage elements. The loading on a logic block output is limited only by the additional propagation delay of the interconnect network. Performance of the logic block is a function of supply voltage and temperature, as shown in Figure 19.

Interconnect Performance

Interconnect performance depends on the routing resource used to implement the signal path. As discussed earlier, direct interconnect from block to block provides a minimum delay path for a signal.

The single metal segment used for Longlines exhibits low resistance from end to end, but relatively high capacitance. Signals driven through a programmable switch will have the additional impedance of the switch added to their normal drive impedance.

General-purpose interconnect performance depends on the number of switches and segments used, the presence of the bidirectional repowering buffers and the overall

loading on the signal path at all points along the path. In calculating the worst-case delay for a general interconnect path, the delay calculator portion of the XACT development system accounts for all of these elements. As an approximation, interconnect delay is proportional to the summation of totals of local metal segments beyond each programmable switch. In effect, the delay is a sum of R-C delays each approximated by an R times the total C it drives. The R of the switch and the C of the interconnect are functions of the particular device performance grade. For a string of three local interconnects, the approximate delay at the first segment, after the first switch resistance, would be three units; an additional two delay units after the next switch plus an additional delay after the last switch in the chain. The interconnect R-C chain terminates at each repowering buffer. Nearly all of the capacitance is in the interconnect metal and switches; the capacitance of the block inputs is not significant.

Power

Power Distribution

Power for the LCA is distributed through a grid to achieve high noise immunity and isolation between logic and I/O. For packages having more than 48 pins, two V_{CC} pins and two ground pins are provided (see Figure 20). Inside the LCA device, a dedicated V_{CC} and ground ring surrounding the logic array provides power to the I/O drivers. An

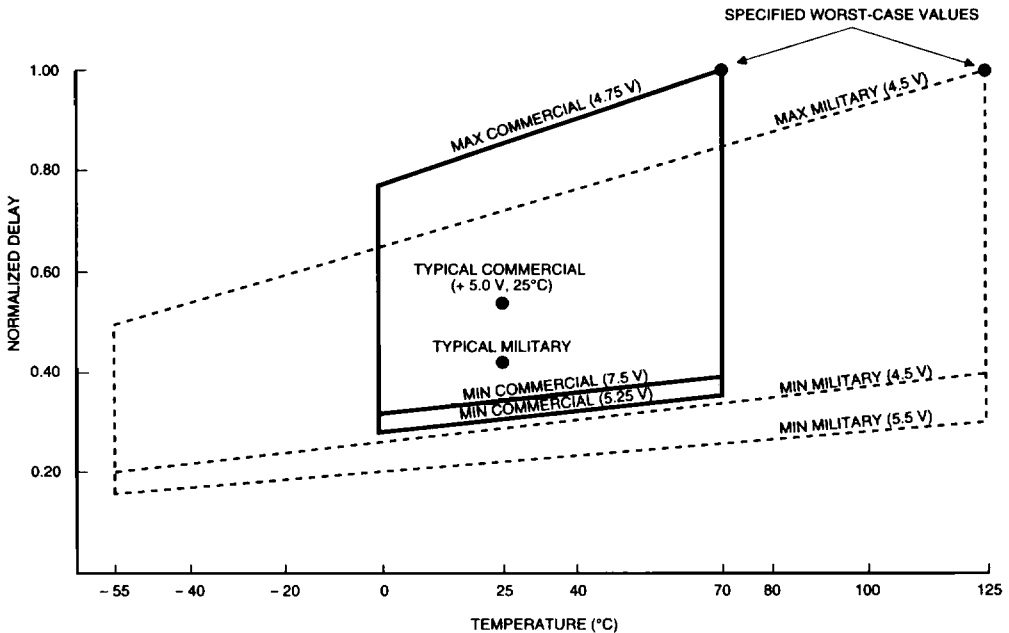

X1045

Figure 19. Relative Delay as a Function of Temperature, Supply Voltage and Processing Variations

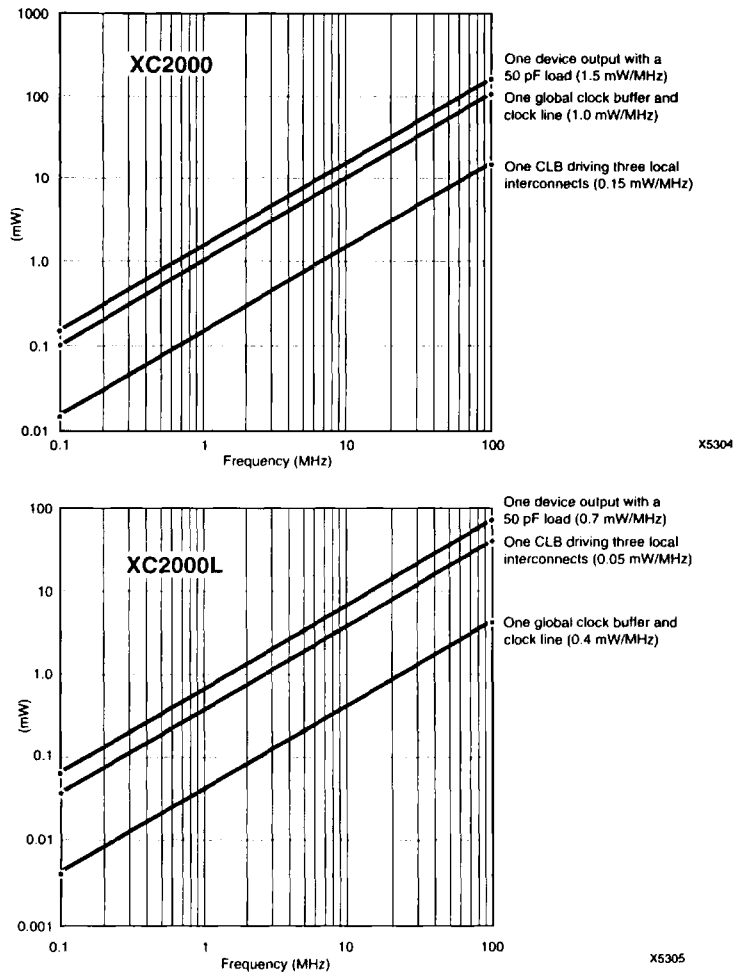

Figure 20. Typical Power Consumption by Element

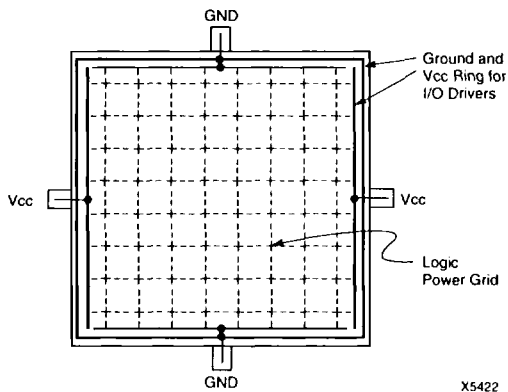

Figure 21. LCA Power Distribution

independent matrix of V_{CC} and ground lines supplies the interior logic of the device. This power distribution grid provides a stable supply and ground for all internal logic, providing the external package power pins are appropriately decoupled. Typically a $0.1 \mu\text{F}$ capacitor connected between the V_{CC} and ground pins near the package will provide adequate decoupling.

Output buffers capable of driving the specified 4 mA loads under worst-case conditions may be capable of driving 25 to 30 times that current in a best case. Noise can be reduced by minimizing external load capacitance and reducing simultaneous output transitions in the same direction. It may also be beneficial to locate heavily loaded output buffers near the ground pads. Multiple V_{CC} and ground pin connections are required for package types which provide them.

Power Consumption

The Logic Cell Array exhibits the low power consumption characteristic of CMOS ICs. Only quiescent power is required for the LCA configured for CMOS input levels. The TTL input level configuration option requires additional power for level shifting. The power required by the static memory cells which hold the configuration data is very low and may be maintained in a power-down mode.

Typically most of power dissipation is produced by capacitive loads on the output buffers, where the incremental power consumption is $25 \mu\text{W} / \text{pF} / \text{MHz}$. Another component of I/O power is the dc loading on each output pin. For any given system, the user can calculate the I/O power requirement based on the sum of capacitive and resistive loading of the devices driven by the Logic Cell Array.

Internal power supply dissipation is a function of clock frequency and the number of nodes changing on each clock. In an LCA the fraction of nodes changing on a given clock is typically low (10–20%). For example, in a 16-bit binary counter, the average clock produces a change in slightly less than 2 of the 16 bits. In a 4-input AND gate there will be 2 transitions in 16 states. Typical global clock buffer power is about $2.5 \text{ mW} / \text{MHz}$ for the XC2064 and $3.2 \text{ mW} / \text{MHz}$ for the XC2018. With a typical load of three general interconnect segments, each Configurable Logic Block output requires about $0.22 \text{ mW} / \text{MHz}$ of its output frequency. At 3.3 V, the dynamic power consumption is reduced by the square of the voltage ratio, i.e., about 56%.

Dynamic Power Consumption

XC2018 at 5.0V

One CLB driving three local interconnects	0.22 mW/MHz
One device output with a 50-pF load	2.0 mW/MHz
One global clock buffer and line	3.2 mW/MHz

Pin Descriptions

Permanently Dedicated Pins.

V_{CC}

One or two (depending on package type) connections to the nominal +5 V supply voltage. All must be connected.

GND

One or two (depending on package type) connections to ground. All must be connected.

PWRDWN

A Low on this CMOS-compatible input stops all internal activity, but retains configuration. All flip-flops and latches are reset, all outputs are 3-stated, and all inputs are interpreted as High, independent of their actual level. While PWRDWN is Low, V_{CC} may be reduced to any value >2.3 V. When PWRDWN returns High, the LCA becomes operational with DONE Low for two cycles of the internal 1-MHz clock. During configuration, PWRDWN must be High. If not used, PWRDWN must be tied to V_{CC}.

RESET

This is an active Low input which has three functions.

Prior to the start of configuration, a Low input will delay the start of the configuration process. An internal circuit senses the application of power and begins a minimal time-out cycle. When the time-out and RESET are complete, the levels of the M lines are sampled and configuration begins.

If RESET is asserted during a configuration, the LCA device is re-initialized and restarts the configuration at the termination of RESET.

If RESET is asserted after configuration is complete, it provides a global asynchronous reset of all IOB and CLB storage elements of the LCA device.

RESET can also be used to recover from partial power failure. See section on Re-program under "Special Configuration Functions."

CCLK

During configuration, Configuration Clock is an output of an LCA in Master mode or Peripheral mode, but an input in Slave mode. During a Readback, CCLK is a clock input for shifting configuration data out of the LCA.

CCLK drives dynamic circuitry inside the LCA. The Low time may, therefore, not exceed a few microseconds. When used as an input, CCLK must be "parked High". An internal pull-up resistor maintains High when the pin is not being driven.

DONE/PROG (D/P)

DONE is an open-drain output, configurable with or without an internal pull-up resistor. At the completion of configuration, the LCA circuitry becomes active in a synchronous order; DONE goes active High one cycle after the IOB outputs go active.

Once configuration is done, a High-to-Low transition of this pin will cause an initialization of the LCA and start a reconfiguration.

M0/RTRIG

As Mode 0, this input and M1, M2 are sampled before the start of configuration to establish the configuration mode to be used.

A Low-to-High input transition, after configuration is complete, acts as a Read Trigger and initiates a Readback of configuration and storage-element data clocked by CCLK. By selecting the appropriate Readback option when generating the bitstream, this operation may be limited to a single Readback, or be inhibited altogether.

M1/RDATA

As Mode 1, this input and M0, M2 are sampled before the start of configuration to establish the configuration mode to be used. If Readback is never used, M1 can be tied directly to ground or V_{CC} . If Readback is ever used, M1 must use a 5-k Ω resistor to ground or V_{CC} , to accommodate the RDATA output.

As an active Low Read Data, after configuration is complete, this pin is the output of the Readback data.

User I/O Pins that can have special functions.

M2

During configuration, this input has a weak pull-up resistor. Together with M0 and M1, it is sampled before the start of configuration to establish the configuration mode to be used. After configuration, this pin is a user-programmable I/O pin.

HDC

During configuration, this output is held at a High level to indicate that configuration is not yet complete. After configuration, this pin is a user-programmable I/O pin.

LDC

During Configuration, this output is held at a Low level to indicate that the configuration is not yet complete. After configuration, this pin is a user-programmable I/O pin. LDC is particularly useful in Master mode as a Low enable for an EPROM, but it must then be programmed as a High after configuration.

XTL1

This user I/O pin can be used to operate as the output of an amplifier driving an external crystal and bias circuitry.

XTL2

This user I/O pin can be used as the input of an amplifier connected to an external crystal and bias circuitry. The I/O Block is left unconfigured. The oscillator configuration is activated by routing a net from the oscillator buffer symbol output and by the MakeBits program.

CS0, CS1, CS2, WRT

These four inputs represent a set of signals, three active Low and one active High, that are used to control configuration-data entry in the Peripheral mode. Simultaneous assertion of all four inputs generates a Write to the internal data buffer. The removal of any assertion clocks in the D0-D7 data. In Master mode, these pins become part of the parallel configuration byte, D4, D3, D2, D1. After configuration, these pins are user-programmable I/O pins.

RCLK

During Master mode configuration RCLK represents a "read" of an external dynamic memory device (normally not used). After configuration, this is a user-programmable I/O pin.

D0-D7

This set of eight pins represents the parallel configuration input for the parallel Master mode. After configuration is complete they are user programmed I/O pins.

A0-A15

During Master Parallel mode, these 16 pins present an address output for a configuration EPROM. After configuration, they are user-programmable I/O pins.

DIN

During Slave or Master Serial configuration, this pin is used as a serial-data input. In the Master or Peripheral configuration, this is the Data 0 input. After configuration, this is a user-programmable I/O pin.

DOUT

During configuration this pin is used to output serial-configuration data to the DIN pin of a daisy-chained slave. After configuration, this is a user-programmable I/O pin.

Unrestricted User I/O Pins.

I/O

An I/O pin may be programmed by the user to be an Input or an Output pin following configuration. All unrestricted I/O pins, plus the special pins mentioned on the following page, have a weak pull-up resistor of 40 to 100 k Ω that becomes active as soon as the device powers up, and stays active until the end of configuration.

XC2064 Configuration Pin Assignments

Configuration Mode: <M2:M1:M0>					44	48	68	68	User					
MASTER-SET <0:0:0>	SLAVE <1:1:1>	PERIPHERAL <1:0:1>	MASTER-HIGH <1:1:0>	MASTER-LOW <1:0:0>	PLCC	DIP	PLCC	PGA	Operation					
GND					1		1	B6	GND					
<<HIGH>>					A13 (O)		2	A6	I/O					
					A6 (O)	2	1	3		B5				
					A12 (O)			4		A5				
					A7 (O)	3	2	5		B4				
					A11 (O)	4	3	6		A4				
					A8 (O)	5	4	7		B3				
					A10 (O)	6	5	8		A3				
PWRDWN (I)					7	6	9	A2	PWR DWN					
<<HIGH>>					8	7	10	B2	I/O					
					9	8	11	B1						
					10		12	C2						
					11	9	13	C1						
							14	D2						
						10	15	D1						
VCC					11	17	E1	VCC						
<<HIGH>>					12	12	18	F2	I/O					
					13	13	19	F1						
					14		20	G2						
					15	14	21	G1						
							22	H2						
						15	23	H1						
						16	24	J2						
M1 (LOW)	M1 (HIGH)	M1 (LOW)	M1 (HIGH)	M1 (LOW)	16	17	25	J1	RDATA (O)					
M0 (LOW)	M0 (HIGH)	M0 (HIGH)	M0 (LOW)	M0 (LOW)	17	18	26	K1	RTRIG (I)					
M2 (LOW)					18	19	27	K2	I/O					
HDC (HIGH)					19	20	28	L2						
<<HIGH>>							29	K3						
LDC (LOW)					20	21	30	L3						
<<HIGH>>							31	K4						
<<HIGH>>					21	22	32	L4	I/O					
					22		33	K5						
						23	34	L5						
						24	35	K6						
GND					23	24	35	K6	GND					
<<HIGH>>							36	L6	I/O					
							37	K7						
							38	L7						
							39	K8						
							40	L8						
							41	K9						
							42	L9						
D7 (I)					24	28	41	K9	XTL2 OR I/O					
D6 (I)					25	29	42	L9						
RESET (I)					26	30	43	L10	RESET					
DONE (O)					27	31	44	K10						
<<HIGH>>					28	32	45	K11	XTL1 OR I/O					
					29	33	46	J10						
							47	J11						
							48	H10						
D5 (I)					30	34	48	H10	I/O					
CS0 (I)					31	35	50	G10						
CS1 (I)					32	36	51	G11						
Vcc					33		52	F10	VCC					
<<HIGH>>							53	F11	I/O					
					CS2 (I)					34	37	54	E10	
					WRT (I)							55	E11	
RCLK					35	38	56	D10	I/O					
DIN (I)						39	57	D11						
DOUT (O)					36	40	58	C10	I/O					
CCLK (O)	CCLK (I)	CCLK (O)			37	41	59	C11						
<<HIGH>>					38	42	60	B11	I/O					
					A0 (O)	39	43	61		B10				
					A1 (O)	40	44	62		A10				
					A2 (O)	41	45	63		B9				
					A3 (O)	42	46	64		A9				
					A15 (O)			65		D8				
					A4 (O)	43	47	66		A8				
A14 (O)			67	B7										
A5 (O)	44	48	68	A7										

<<HIGH>> is high impedance with a 20-50 kΩ internal pull-up during configuration

X6103

Note: A PLCC in a "PGA-Footprint" socket has a **different** signal pinout than a PGA device.

XC2018 Configuration Pin Assignments

CONFIGURATION MODE: <M2:M1:M0>					44	64	88	84	84	100	USER OPERATION						
MASTER-SER <0:0>	SLAVE <1:1>	PERIPHERAL <1:0:1>	MASTER-HIGH <1:0>	MASTER-LOW <1:0>	PLCC	VOFP	PLCC	PLCC	PGA	TQFP							
GND					1	8	1	1	C6	13	GND						
<<HIGH>>					A13 (O)		9	2	A6	14	IO						
					3	A5	15										
					4	B5	16										
					2	A8 (O)	10	3	C5	17							
					11	A12 (O)	4	6	A4	18							
					3	A7 (O)	12	5	B4	19							
					4	A11 (O)	13	6	A3	20							
					5	A8 (O)	14	7	A2	21							
					6	A10 (O)	15	8	B3	22							
FWRDWN (I)					7	16	9	11	A1	23	PWR DWN						
<<HIGH>>					8	17	10	12	B2	26	IO						
					9	18	11	13	C2	27							
					19	12	14	B1	29								
					10	20	13	15	C1	30							
					14	16	D2	32									
					11	21	15	17	D1	33							
					18	E3	34										
					22	18	E2	35									
					20	E1	36										
					23	17	F2	37									
Vcc					12	24	18	22	F3	38	Vcc						
<<HIGH>>					25	19	23	G3	39	IO							
					24	G1	40										
					13	26	20	25	G2		41						
					26	F1	42										
					14	27	21	27	H1		43						
					28	22	28	H2	45								
					15	29	23	29	J1		47						
					30	24	30	K1	48								
					M1 (LOW) M1 (HIGH) M1 (LOW) M1 (HIGH) M1 (LOW)						16	31	25	31	J2	49	RDATA (O)
					M0 (LOW) M0 (HIGH) M0 (LOW) M0 (HIGH) M0 (LOW)						17	32	26	32	L1	51	RTRIG (I)
M2 (LOW) M2 (HIGH)					18	33	27	33	K2	53	IO						
HDC (HIGH)					19	34	28	34	K3	54							
<<HIGH>>					36	29	35	L2	55								
LDC (LOW)					20	36	30	36	L3	56							
<<HIGH>>					37	31	37	K4	57								
					21	38	32	38	L4	58							
					39	33	40	K5	60								
					40	34	41	L5	61								
					42	K6	62										
					23	41	35	43	J6	63							
GND					24	45	41	51	L10	71	IO						
<<HIGH>>					42	36	45	L7	65								
					37	46	K7	66									
					43	38	47	L8	67								
					48	L8	68										
					44	39	49	K8	69								
					40	50	L9	70									
D7 (I)					24	45	41	51	L10	71							
D6 (I)					25	46	42	52	K9	72							
RESET (I)					26	47	43	53	L11	73		XTL2 OR IO					
DONE (O)					27	48	44	54	K10	75	RESET						
<<HIGH>>					28	49	45	55	J10	77	PROG (I)						
					29	50	46	56	K11	78	XTL1 OR IO						
D5 (I)					30	52	48	58	H10	80	IO						
<<HIGH>>					51	47	57	J11	79								
					59	H11	82										
					53	49	60	F10	84								
					61	G10	85										
CS0 (I) D4 (I)					31	54	50	62	G11	86							
CS1 (I) D3 (I)					32	55	51	63	G9	87							
Vcc					33	56	52	64	F9	88		Vcc					
<<HIGH>>					57	53	65	F11	89								
					34	58	54	66	E11	90							
					67	E10	91										
					59	55	68	E9	92								
					69	D11	93										
					70	D10	95										
WRT (I) D1 (I)					36	60	56	70	D10	95	IO						
RCLK					61	57	71	C11	98								
DIN (I) D0 (I)					36	62	58	72	B11	97							
DOUT (O)					37	63	59	73	C10	98							
CCLK (O) CCLK (I) CCLK (O)					38	64	60	74	A11	99		CCLK (I)					
<<HIGH>>					39	1	61	75	B10	2							
					40	2	62	76	B9	3							
					41	3	63	77	A10	5							
					42	4	64	78	A9	6							
					65	79	B8	7									
					43	5	66	80	A8	8							
					6	67	81	B6	9								
					82	B7	10										
83	A7	11															
A5 (O)					44	7	68	84	C7	12							

<<HIGH>> IS HIGH IMPEDANCE WITH A 20-50 kΩ INTERNAL PULL-UP DURING CONFIGURATION

X3461

XC2000 Logic Cell Array Families

For a detailed description of the device architecture, see pages 2-187 through 2-195.

For a detailed description of the configuration modes and their timing, see pages 2-200 through 2-208.

For package physical dimensions and thermal data, see Section 4.

Ordering Information

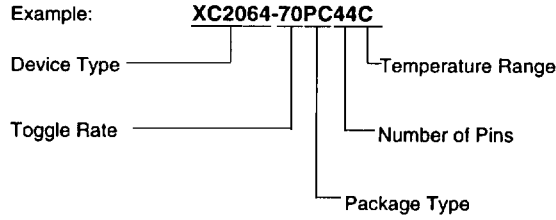

Component Availability

PINS	44	48	64	68		84		100	
TYPE	PLAST. PLCC	PLAST. DIP	PLAST. VQFP	PLAST. PLCC	CERAM. PGA	PLAST. PLCC	CERAM. PGA	PLAST. TQFP	PLAST. VQFP
CODE	PC44	PD48	VQ64	PC68	PG68	PC84	PG84	TQ100	VQ100
XC2064	-50				M				
	-70	CI		CI	CI M				
	-100	CI		CI	CI				
	-130	C		C	C				
XC2018	-33						MB		
	-50						MB		
	-70	CI		CI		CI	CI MB		
	-100	CI		CI	CI	CI	CI	CI	
	-130	C		C	C	C	C	C	
XC2064L			C	C					
XC2018L			C			C			C

C = Commercial = 0° to +85° C I = Industrial = -40° to +100° C
M = Mil Temp = -55° to +125° C B = Mil-STD-883C Class B

X6120



XC2000 Logic Cell Array Family

Product Specifications

Features

- Fully Field-Programmable:
 - I/O functions
 - Digital logic functions
 - Interconnections
- General-purpose array architecture
- Complete user control of design cycle
- Compatible arrays with logic cell complexity equivalent from 600 to 1,500 gates
- Standard product availability
- 100% factory-tested
- Selectable configuration modes
- Low-power, CMOS, static-memory technology
- Performance equivalent to TTL SSI/MSI
- TTL or CMOS input thresholds
- Complete development system support
 - XACT Design Editor
 - Schematic Entry
 - Macro Library
 - Timing Calculator
 - Logic and Timing Simulator
 - Auto Place/Route

Description

The Logic Cell Array (LCA) is a high density CMOS integrated circuit. Its user-programmable array architecture is made up of three types of configurable elements: Input/Output Blocks, logic blocks and Interconnect. The designer can define individual I/O blocks for interface to external circuitry, define logic blocks to implement logic functions and define interconnection networks to compose larger scale logic functions. The XACT Development System provides interactive graphic design capture and automatic routing. Both logic simulation and in-circuit emulation are available for design verification.

The Logic Cell Array is available in a variety of logic capacities, package styles, temperature ranges and speed grades.

Device	Logic Capacity (gates)	CLBs	User I/O Max	Config. bits
XC2064	600 - 1,000	64	58	12038
XC2018	1,000 - 1,500	100	74	17878

The LCA logic functions and interconnections are determined by data stored in internal static-memory cells. On-chip logic provides for automatic loading of configuration data at power-up. The program data can reside in an EEPROM, EPROM or ROM on the circuit board or on a floppy disk or hard disk. The program can be loaded in a number of modes to accommodate various system requirements.

Xilinx maintains test specifications for each product as controlled documents. To insure the use of the most recently released device performance parameters, please request a copy of the current test-specification revision.

Absolute Maximum Ratings

Symbol	Description		Units
V _{CC}	Supply voltage relative to GND	-0.5 to +7.0	V
V _{IN}	Input voltage with respect to GND	-0.5 to V _{CC} +0.5	V
V _{TS}	Voltage applied to 3-state output	-0.5 to V _{CC} +0.5	V
T _{STG}	Storage temperature (ambient)	-65 to +150	°C
T _{SOL}	Maximum soldering temperature (10 s @ 1/16 in.)	+260	°C

Note: Stresses beyond those listed under Absolute Maximum Ratings may cause permanent damage to the device. These are stress ratings only, and functional operation of the device at these or any other conditions beyond those listed under Recommended Operating Conditions is not implied. Exposure to Absolute Maximum Ratings conditions for extended periods of time may affect device reliability.

Operating Conditions

Symbol	Description	Min	Max	Units
V _{CC}	VCC relative to GND Commercial 0°C to +85°C junction	4.75	5.25	V
	VCC relative to GND Industrial -40°C to +100°C junction	4.5	5.5	V
	VCC relative to GND Military -55°C to +125°C case	4.5	5.5	V
V _{IHT}	High-level input voltage — TTL configuration	2.0	V _{CC}	V
V _{ILT}	Low-level input voltage — TTL configuration	0	0.8	V
V _{IHC}	High-level input voltage — CMOS configuration	70%	100%	V _{CC}
V _{ILC}	Low-level input voltage — CMOS configuration	0	20%	V _{CC}
T _{IN}	Input signal transition time		250	ns

At junction temperatures above those listed as Operating Conditions, all delay parameters increase by 0.3% per °C.

DC Characteristics Over Operating Conditions

Symbol	Description		Min	Max	Units
V_{OH}	High-level output voltage (@ $I_{OH} = -4.0$ ma V_{CC} min)	Commercial	3.86		V
V_{OL}	Low-level output voltage (@ $I_{OL} = 4.0$ ma V_{CC} min)			0.32	V
V_{OH}	High-level output voltage (@ $I_{OH} = -4.0$ ma V_{CC} min)	Industrial Military	3.76		V
V_{OL}	Low-level output voltage (@ $I_{OL} = 4.0$ ma V_{CC} min)			0.37	V
V_{CCPD}	Power-down supply voltage (\overline{PWRDWN} must be Low)		2.3		V
I_{CCO}	Quiescent operating power supply current				
	CMOS thresholds (@ V_{CC} Max)			5	mA
	TTL thresholds (@ V_{CC} Max)			12	mA
I_{CCPD}	Power-down supply current ($V_{CC(MAX)}$ @ T_{MAX})			500	μ A
I_{IL}	Input Leakage Current		-10	+10	μ A
C_{IN}	Input capacitance (sample tested) All Pins except XTL1 and XTL2 XTL1 and XTL2			10	pF
				15	pF

CLB Switching Characteristic Guidelines

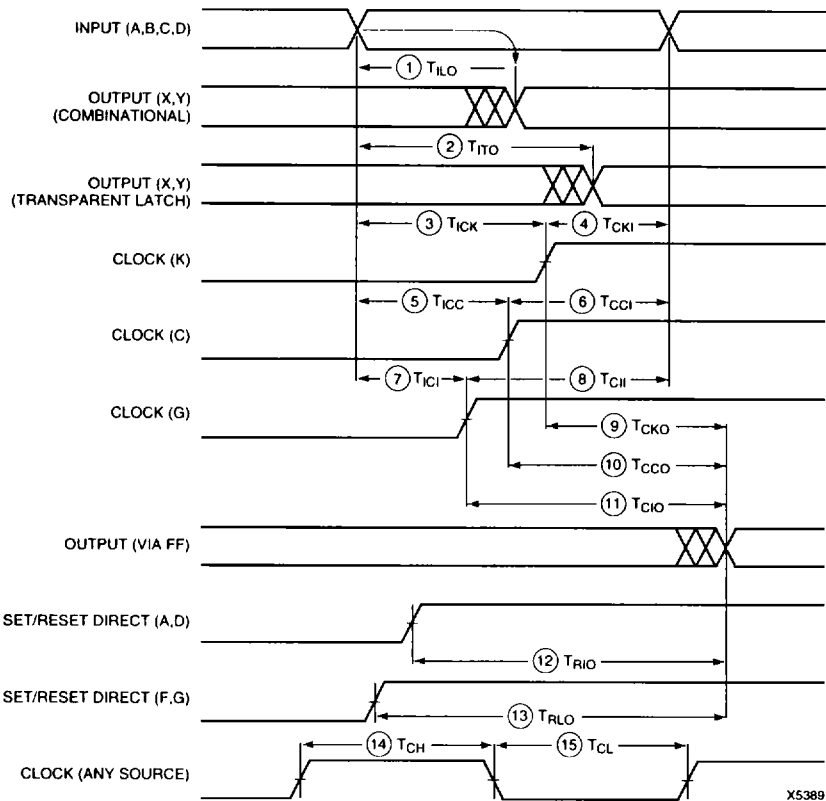

X5389

CLB Switching Characteristic Guidelines (Continued)

Speed Grade			-70		-100		-130		Units	
	Description	Symbol	Min	Max	Min	Max	Min	Max		
Logic Input to Output	Combinatorial Transparent latch Additional for Q through F or G to out	1	T_{ILO}		10		8		5.5	ns
		2	T_{ITO}		14		10		8	ns
			T_{QLO}		6		6		3.7	ns
K Clock	To output Logic-input setup Logic-input hold	9	T_{CKO}		10		7		7	ns
		3	T_{ICK}	7		6		2.5		ns
		4	T_{CKI}	0		0		1.0		ns
C Clock	To output Logic-input setup Logic-input hold	10	T_{CCO}		13		9		7	ns
		5	T_{ICC}	6		5		3		ns
		6	T_{CCI}	0		0		1		ns
Logic Input to G Clock	To output Logic-input setup Logic-input hold	11	T_{CIO}		20		13		13	ns
		7	T_{ICI}	3		2		0		ns
		8	T_{CII}	4		3		5		ns
Set/Reset direct	Input A or D to output x, y Through F or G to output Reset pad to output x, y Separation of set/reset Set/Reset pulse-width	12	T_{RIO}		16		10		8	ns
		13	T_{RLO}		21		14		11	ns
			T_{MRQ}		20		17		13	ns
			T_{RS}	7		6		5		ns
			T_{RPW}	7		6		5		ns
Flip-flop Toggle rate	Q through F to flip-flop		F_{CLK}	70		*100		130		MHz
Clock	Clock High Clock Low	14	T_{CH}	7		*5		3.5		ns
		15	T_{CL}	7		*5		3.5		ns

Notes: 1. All switching characteristics apply to all valid combinations of process, temperature and supply with a nominal chip power dissipation of 250 mW.

* These parameters are for clock pulses generated within a CLB. For an externally generated pulse, derate these parameters by 20%.

I/O Switching Guidelines

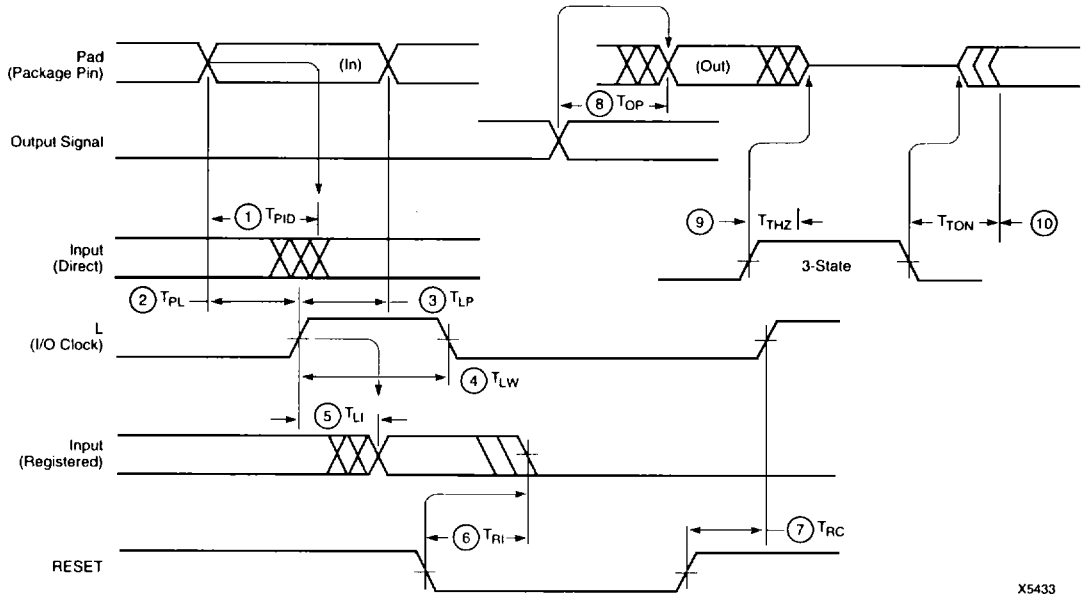

X5433

Speed Grade			-70		-100		-130		Units
	Description	Symbol	Min	Max	Min	Max	Min	Max	
Pad (package pin)	To input (direct)	1 T_{PID}		6		4		3.5	ns
I/O Clock	To input (storage)	5 T_{LI}		11		8		7.5	ns
	To pad-input setup	2 T_{PL}	6		4		2		ns
	To pad-input hold	3 T_{LP}	0		0		4		ns
	Pulse width	4 T_{LW}	7		*5		3.5		ns
	Frequency		70		*100				MHz
Output	To pad (output enabled)	8 T_{OP}		9		7		5.5	ns
Three-state	To pad begin hi-Z	9 T_{THZ}		15		11		7	ns
	To pad end hi-Z	10 T_{TON}		15		13		11	ns
RESET	To input (storage)	6 T_{RI}		25		17		15	ns
	To input clock	7 T_{RC}	20		14		10		ns

Note: Timing is measured at 0.5 Vcc levels with 50 pF output load.

*These parameters are for clock pulses generated within an LCA device. For an externally applied clock, derate these parameters by 20%.



XC2000L Low-Voltage Logic Cell Array Family

Product Specifications

Features

- Part of the ZERO+ Family of 3.3 V FPGAs
- Low-power, low-supply-voltage FPGA family with two device types
 - JEDEC-compliant 3.3 V version of the XC2000 LCA Family
 - Logic densities from 600 to 1,500 gates
 - Up to 74 user-definable I/Os
- Advanced, low power 0.8 μ CMOS static-memory technology
 - Very low quiescent current consumption, $\leq 20 \mu\text{A}$, 25 times less than XC2000
 - Operating power consumption 66% less than previous generation 5 V FPGAs; 56% less than XC2000
- Identical to the basic XC2000 in structure, pin out, design methodology, and software tools
 - 100% compatible with XC2000 bitstreams
- XC2000L-specific features
 - Guaranteed over the 3.0 to 3.6 V V_{CC} range
 - 4 mA output sink and source current
 - Advanced packaging using thin and very thin quad flat packs

Description

The XC2000L family of FPGAs is optimized for operation from a 3.3 V (nominal) supply. Aside from the electrical and timing parameters listed in this data sheet, the XC2000L family is in all respects identical with the XC2000 family.

The operating power consumption of Xilinx FPGAs is almost exclusively dynamic; it changes with the square of the supply voltage. For a given complexity and clock speed, the XC2000L consumes, therefore, only 44% of the power used by the equivalent XC2000 device. Consistent with its use in battery-powered equipment, the XC2000L family was designed for the lowest possible power-down and quiescent current consumption.

Device	Logic Capacity (gates)	CLBs	User I/O Max	Config. bits
XC2064L	600 - 1,000	64	58	12,038
XC2018L	1,000 - 1,500	100	74	17,878

LCA logic functions and interconnections are determined by data stored in internal static-memory cells. On-chip logic provides for automatic loading of configuration data at power-up. Program data can reside in an EEPROM, EPROM or ROM on the circuit board or on a floppy disk or hard disk. The program can be loaded in a number of modes to accommodate various system requirements.

Xilinx maintains test specifications for each product as controlled documents. To insure the use of the most recently released device performance parameters, please request a copy of the current test-specification revision.

Absolute Maximum Ratings

Symbol	Description		Units
V_{CC}	Supply voltage relative to GND	-0.5 to +7.0	V
V_{IN}	Input voltage with respect to GND	-0.5 to $V_{CC} + 0.5$	V
V_{TS}	Voltage applied to 3-state output	-0.5 to $V_{CC} + 0.5$	V
T_{STG}	Storage temperature (ambient)	-65 to +150	°C
T_{SOL}	Maximum soldering temperature (10 s @ 1/16 in.)	+260	°C
T_J	Junction temperature plastic	+125	°C
	Junction temperature ceramic	+150	°C

Note: Stresses beyond those listed under Absolute Maximum Ratings may cause permanent damage to the device. These are stress ratings only, and functional operation of the device at these or any other conditions beyond those listed under Recommended Operating Conditions is not implied. Exposure to Absolute Maximum Ratings conditions for extended periods of time may affect device reliability.

Operating Conditions

Symbol	Description	Min	Max	Units
V_{CC}	VCC relative to GND (Commercial 0°C to +85°C) junction	3.0	3.6	V
V_{IH}	High-level input voltage	2.0	$V_{CC} + 0.3$	V
V_{IL}	Low-level input voltage	0.3	0.8	V
T_{IN}	Input signal transition time		250	ns

At junction temperatures above those listed as Operating Conditions, all delay parameters increase by 0.3% per °C.

Although the present (1994) devices operate over the full supply voltage range from 3.0 to 5.25 V, Xilinx reserves the right to restrict operation to the 3.0 to 3.6 V range later, when smaller device geometries might preclude operation at 5 V.

DC Characteristics Over Operating Conditions

Symbol	Description	Min	Max	Units
V_{OH}	High-level output voltage (@ $I_{OH} = -2.0 \text{ mA}$ V_{CC} min)	2.4		V
V_{OL}	Low-level output voltage (@ $I_{OL} = 4.0 \text{ mA}$ V_{CC} max)		0.4	V
V_{OH}	High-level output voltage (@ $-100 \mu\text{A}$ V_{CC} min)	$V_{CC}-0.2$		V
V_{OL}	Low-level output voltage (@ $100 \mu\text{A}$ V_{CC} min)		0.2	V
V_{CCPD}	Power-down supply voltage ($\overline{\text{PWRDWN}}$ must be Low)	2.3		V
I_{CCO}	Quiescent operating power supply current*		20	μA
I_{CCPD}	Power-down supply current ($V_{CC(\text{MAX})}$ @ T_{MAX})		10	μA
I_{IL}	Input Leakage Current, all I/O pins in parallel	-10	+10	μA
C_{IN}	Input capacitance (sample tested) All Pins except XTL1 and XTL2		10	pF
	XTL1 and XTL2		15	pF

* With no output current loads, no active input or Longline pull-up resistors, all package pins at V_{CC} or GND, and the LCA device configured with a MakeBits tie option. I_{CCO} is in addition to I_{CCPD} .

CLB Switching Characteristic Guidelines

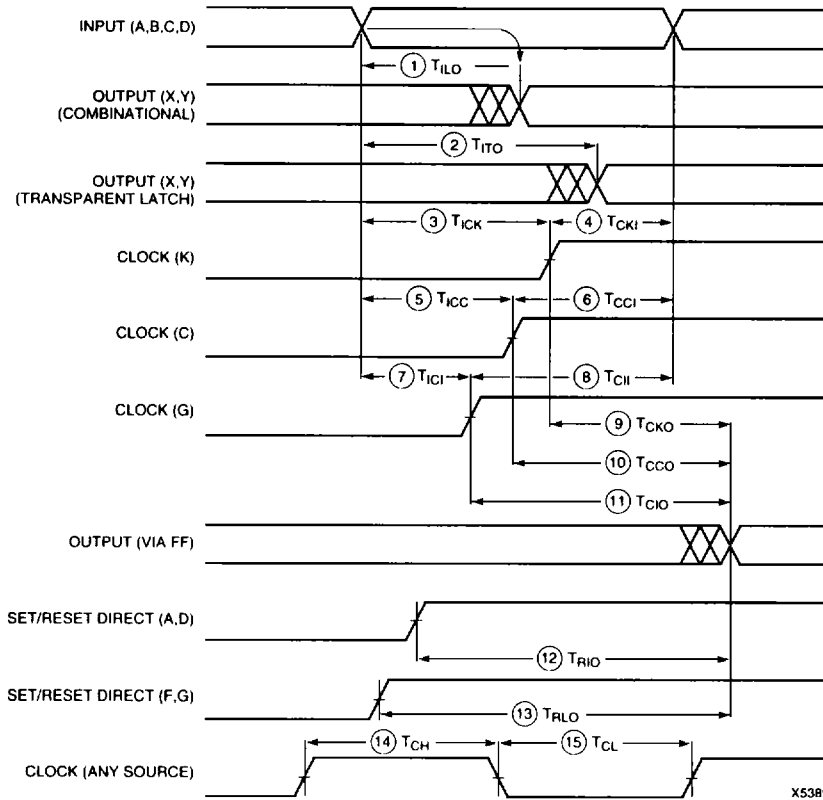

CLB Switching Characteristic Guidelines (Continued)

Speed Grade			-10							
	Description	Symbol		Min	Max					Units
Logic Input to Output	Combinatorial Transparent latch Additional for Q through F or G to out	1	T_{ILO}		9.5					ns
		2	T_{ITO}		14.0					ns
			T_{OLO}		7.0					ns
K Clock	To output Logic-input setup Logic-input hold	9	T_{CKO}		9.5					ns
		3	T_{ICK}	7.0						ns
		4	T_{CKI}	0						ns
C Clock	To output Logic-input setup Logic-input hold	10	T_{CCO}		13.0					ns
		5	T_{ICC}	3.5						ns
		6	T_{CCI}	0						ns
Logic Input to G Clock	To output Logic-input setup Logic-input hold	11	T_{CIO}		20.0					ns
		7	T_{CI}	0						ns
		8	T_{CII}	5.0						ns
Set/Reset direct	Input A or D to output x, y Through F or G to output Reset pad to output x, y Separation of set/reset Set/Reset pulse-width	12	T_{RIO}		10.0					ns
		13	T_{RLO}		17.0					ns
			T_{MRQ}		20.0					ns
			T_{RS}	7.0						ns
			T_{RPW}	7.0						ns
Flip-flop Toggle rate	Q through F to flip-flop		F_{CLK}	70.0						MHz
Clock	Clock High Clock Low	14	T_{CH}	7.0						ns
		15	T_{CL}	7.0						ns

Notes: 1. All switching characteristics apply to all valid combinations of process, temperature and supply with a nominal chip power dissipation of 250 mW.

I/O Switching Guidelines

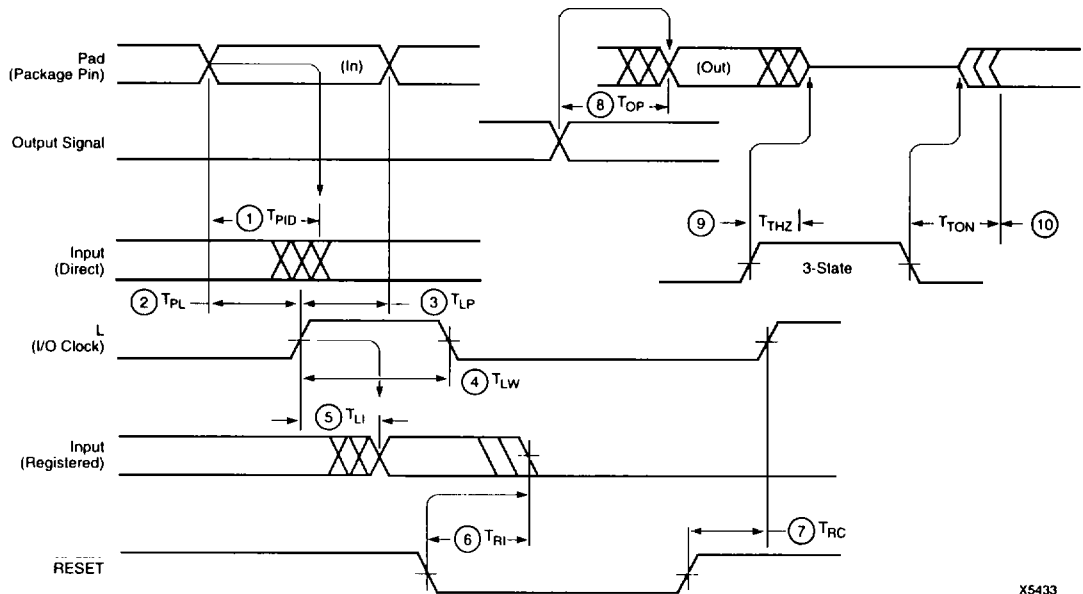

X5433

Speed Grade			-10							
	Description	Symbol	Min	Max						Units
Pad (package pin)	To input (direct)	1 T_{PID}		7.0						ns
I/O Clock	To input (storage)	5 T_{LI}		10.0						ns
	To pad-input setup	2 T_{PL}	5.0							ns
	To pad-input hold	3 T_{LP}	1.0							ns
	Pulse width	4 T_{LW}	7.0							ns
	Frequency									MHz
Output	To pad (output enabled)	8 T_{OP}		10.5						ns
Three-state	To pad begin hi-Z	9 T_{THZ}		15.0						ns
	To pad end hi-Z	10 T_{TON}		20.0						ns
RESET	To input (storage)	6 T_{RI}		25.0						ns
	To input clock	7 T_{RC}	20.0							ns

Note: Timing is measured at 0.5 Vcc levels with 50 pF output load.