



iCE40LM4K Sensor Evaluation Kit

User's Guide

Introduction

Thank you for choosing the Lattice iCE40LM4K Sensor Evaluation Kit. This guide describes how to begin using the iCE40LM4K Sensor Evaluation Kit, an easy-to-use platform for rapidly prototyping system control designs using an iCE40LM FPGA. Along with the evaluation board and accessories, this kit includes a pre-loaded demo that allows communication between the iCE40LM4k Sensor Evaluation Kit and a Qualcomm Snapdragon APQ8060A board (not included in the package and may be purchased from Intrinsic). The content of this user's guide includes an overview of the features of the board and a step by step guide to using the iCE40LM4K Sensor Evaluation Kit with the Qualcomm Snapdragon APQ8060A.

Figure 1. iCE40LM4K Daughter Card

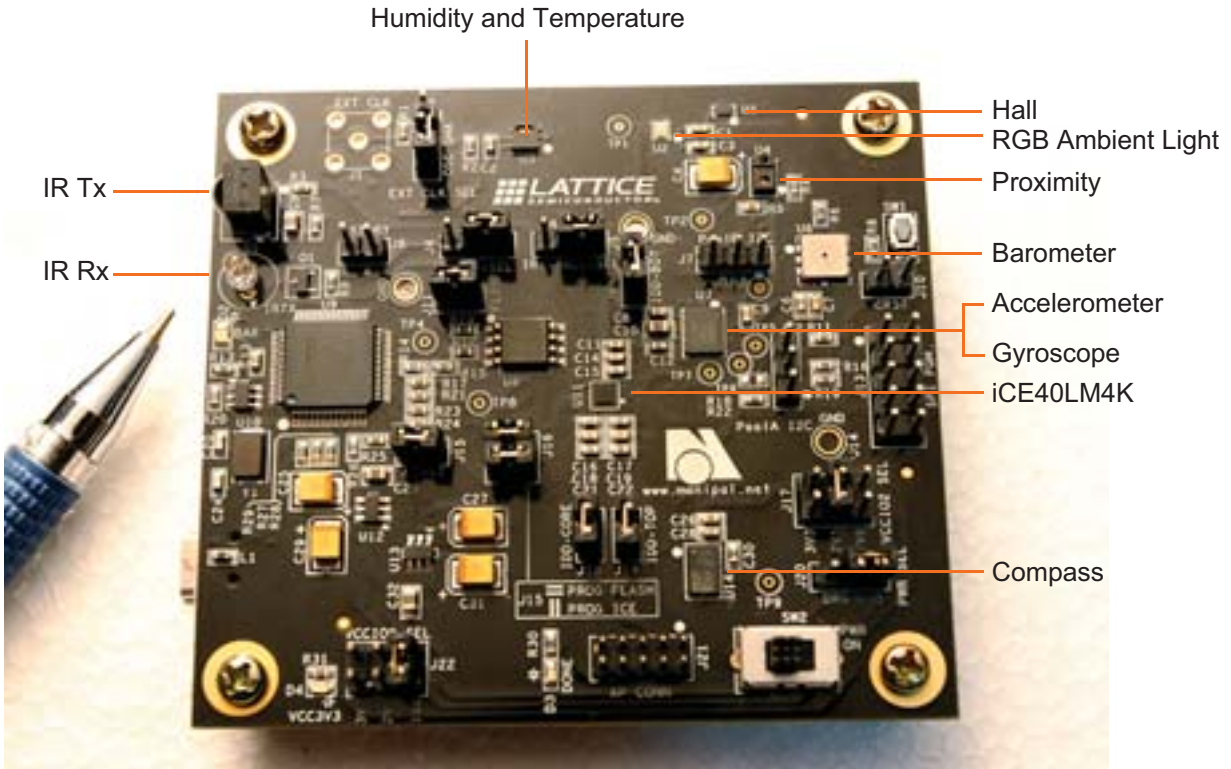

CAUTION: Static electricity can severely shorten the lifespan of electronic components. Be careful when handling the iCE40LM4K Sensor Evaluation Kit to prevent damage from ESD.

Features

The iCE40LM4K Sensor Evaluation Kit includes:

- **iCE40LM4K Evaluation Board** – The ICE40LM4k Evaluation Board features the following on-board components and circuits:
 - iCE40LM4K Device in the 25 WLCSP Package
 - High-Current LED Output
 - Infrared Transmit and Receive
 - Barcode LED/Emulation
 - Configuration SPI Flash
 - On-board FT2232HL for USB Programming/Interface
 - Numerous Sensors
 - Proximity Sensor (AMS-TAOS TMD27711)
 - RGB Color, Infrared, and Temperature Sensors (Maxim MAX44006)
 - Barometric Pressure Sensor (Bosch BMP085)
 - Accelerometer and Gyro (ST Micro LSM330DLC)
 - Magnetometer/Compass/Accelerometer (ST Micro LSM303DLHCTR)
 - Humidity and Temperature Sensor (Sensirion SHT20)
 - Hall Sensor (Rohm BU52051NVX)
- **SMA Connector for External Clock Input**
- **On-Board Oscillator**

In addition to the iCE40LM4K Evaluation Board, an adapter board for connection to Dragon Board and a connector cable are also included. This secondary PCB connected by a cable allows the iCE40LM4k Sensor Evaluation Kit to interface with a Qualcomm 8060A Dragon Board (Dragon Board is available separately and not sold by Lattice). When connected properly, a sensor hub demonstration can be conducted.

Sensor Hub Demo Setup

The demo setup consists of the Intrinsic Dragon Board Gen2, Sensor Fusion Board, and flexible connecting cable.

To set up the Sensor Hub demo, connect the Sensor Fusion Board to the Intrinsic Adapter board which is placed on the Intrinsic Dragon Board Gen2 as shown in Figure 2

Figure 2. Intrinsic Dragon Board Gen2

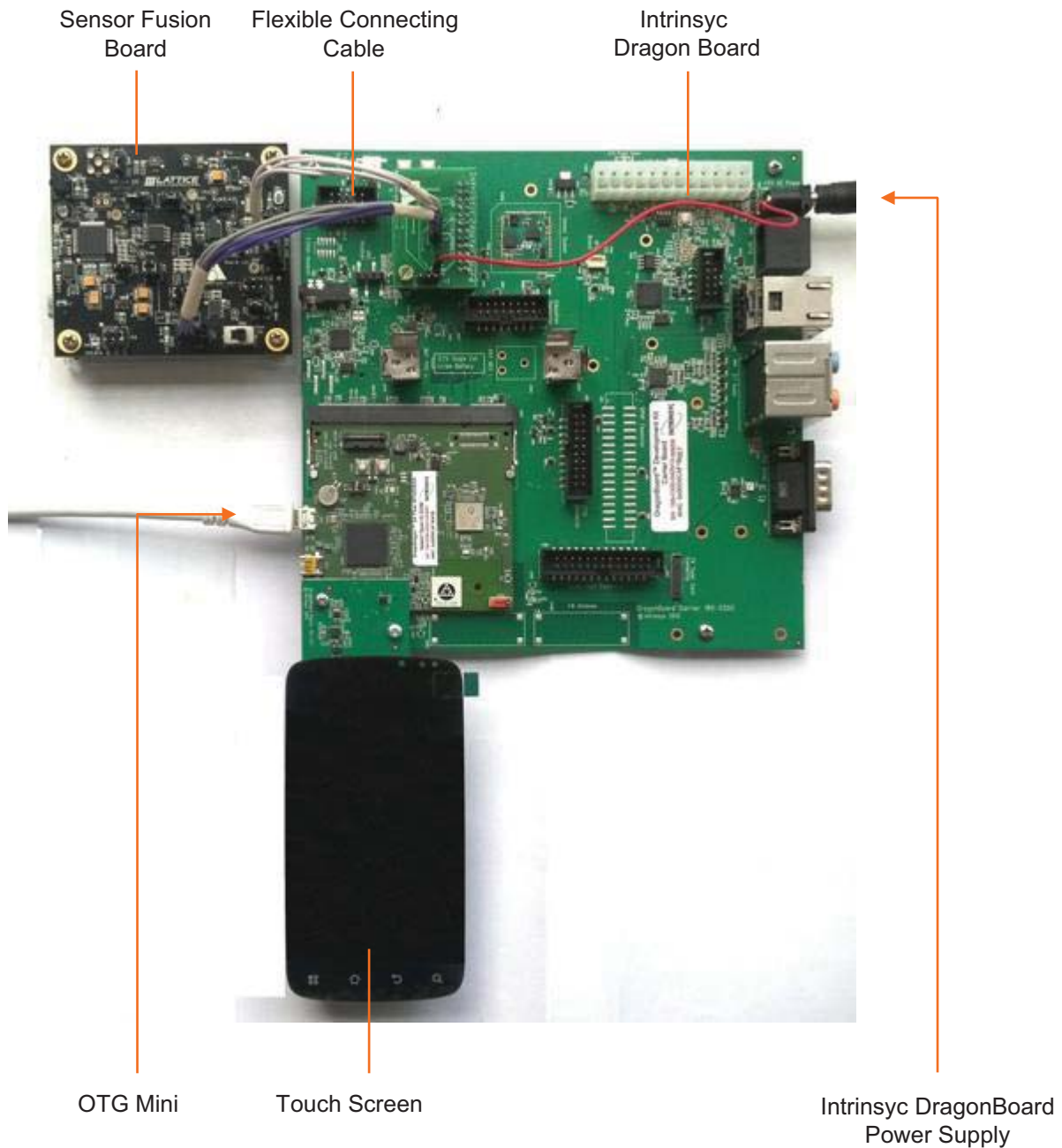

Sensor Fusion Board Default Jumper Settings

This section provides the details of the Sensor Fusion Board jumper settings:

- Set J2 jumper on OSC mode in EXT CLK.
- Set J4 jumper on BAR.
- Set J5 jumper on HALL.
- Do not set J7 jumper.
- Set J8 jumper.
- Do not set J10 jumper.
- Do not set J11 jumper.
- Set J12 jumper.
- Do not set J15 jumper.
- Set both the J16 jumpers vertically.
- Set jumper on IDD-CORE and IDD-TOP (J18 & J19).
- Set VCCIO0 (J22) to 1.8V.
- Set VCCIO2 (J17) set to 3.3V.
- Set J20 jumper on USB mode.

Connecting the Sensor Fusion Board to the Intrinsic Dragon Board

To connect the Sensor Fusion Board to the Intrinsic Dragon Board

1. Power-off the Intrinsic Dragon Board.
2. Connect the Intrinsic Dragon Board end of the processor configuration cable to the Intrinsic Adapter board mounted on the Intrinsic Dragon Board.
 - i. The marked pin of the cable connector should be connected to pin 1 of the connector on the Intrinsic Adapter board near the white dot.
3. Connect the smaller connector on other end of the cable to the J21 connector of the Sensor Fusion Board.
 - i. The marked pin of the cable connector should be connected to pin 1 of the J21 connector near the white dot.
4. Connect the larger connector on the other end of the cable to the J13 connector of the Sensor Fusion Board.
 - i. The marked pin of the cable connector should be connected to pin 1 of the J21 connector near the white dot.
5. Power-on the Intrinsic Dragon Board after the above connections are completed.

Note: Do not connect the mini USB power cable to the Sensor Fusion Board when it is connected to the Intrinsic Dragon Board.

Figure 3 shows the connections between the Sensor Fusion Board and the Intrinsic Dragon Board.

Figure 3. Connecting Sensor Fusion Board to Intrinsic Dragon Board

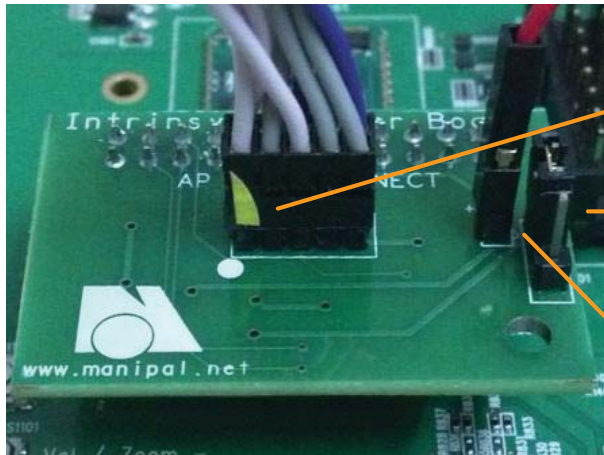

Marked end of cable connected to pin1 of the Intrinsic Adapter board

Jumper to be set at 3.3V

5V fly wire (supplied) to be connected between +5V on the Intrinsic Adapter board (plugged in) and the C1300 right side terminal (soldered) on the Intrinsic Dragon Board

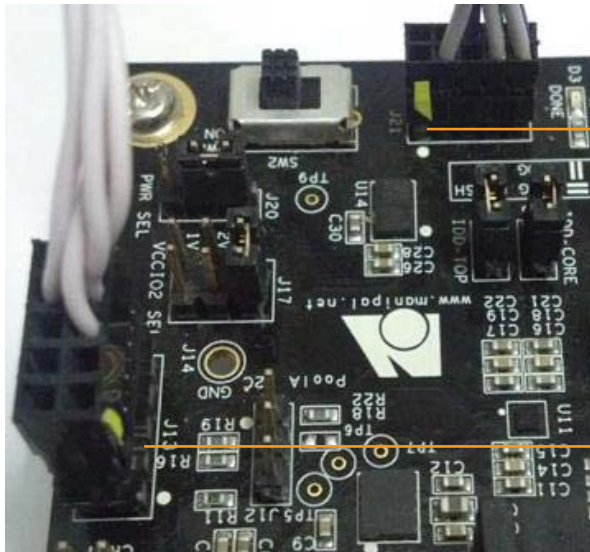

Marked end of smaller connector, connected to pin1 of J21 on the Sensor Fusion Board

Marked end of larger connector, connected to pin1 of J13 on the Sensor Fusion Board

Sensor Fusion Board Details

Figure 4 shows the details of the Sensor Fusion Board.

Figure 4. Sensor Fusion Board

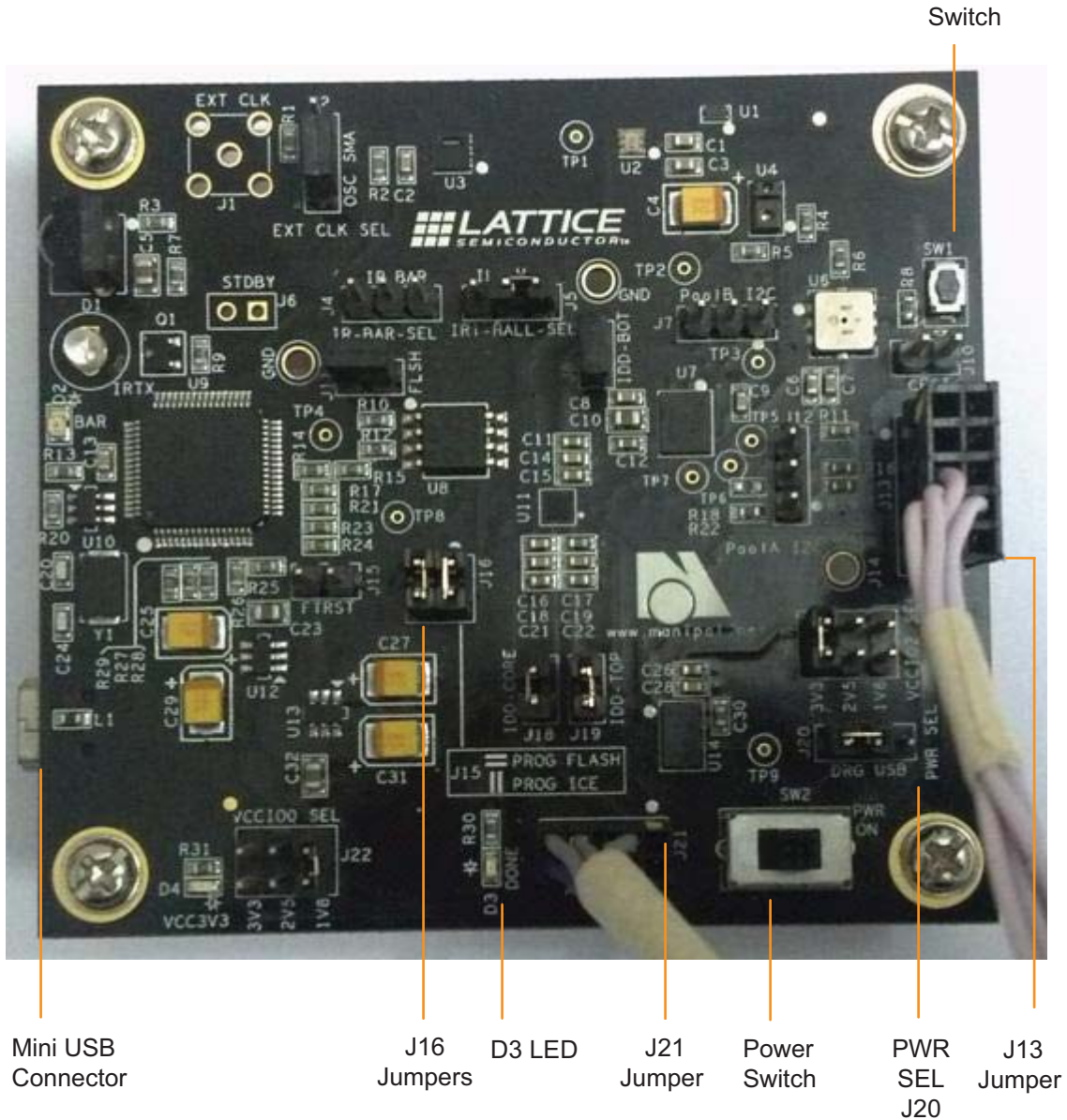

Flashing System Image and Boot Image to Intrinsic Dragon Board

Note that this procedure is not required if the Intrinsic Dragon Board has already been flashed with the system image and boot image (cd *Lightning_Demos_Drop_WITH_APK_INSTALL/Dragonboard_boot_images/*).

To flash the system image and boot image to the Intrinsic Dragon Board:

1. Connect the Intrinsic Dragon Board USB port to your host system through the OTG (mini-USB).
 - i. Download and install android-sdk. Android-sdk for Linux and Windows environment at <http://developer.android.com/sdk/index.html>.

Set <Installation path>/android_sdk/platform-tools/ to the PATH variable.
2. Run the command below in the terminal/command prompt.
`#sudo -s`

Note: This command is applicable only for Linux machines. For Windows machine administrative permission is necessary.
3. Reboot the Intrinsic Dragon Board in fastboot mode.
 - i. Keep Button Vol / Zoom + pressed on the Intrinsic Dragon Board during restart.
If the board is already On in adb mode, use the command below for fastboot mode
`#adb reboot bootloader`
 - ii. When the Intrinsic Dragon Board is in FASTBOOT mode, a white screen comes on with only Intrinsic name displayed on it.
 - iii. Execute the command below in the terminal/command prompt to list the fastboot device number and its name.
`#fastboot devices`

The board is now ready to be flashed with boot.img.

4. Enter the command below to flash system image.
`#fastboot flash system system.img`

If flashing is successful, OKAY and Finished comments are displayed on the terminal.
5. Enter the command below to flash boot.img
`#fastboot flash boot boot.img`

If flashing is successful, OKAY and Finished comments are displayed on the terminal.
6. Enter the command below reboot the board for current boot.img.
`#fastboot reboot`
7. After reboot, go to **Settings > Developer options > Stay awake**.

Installing Sensor Hub apk to Android

To flash the system image and boot image to the Intrinsic Dragon Board:

1. Connect the Intrinsic Dragon Board USB port to your host system through the OTG (mini-USB).
2. Run the command below in the terminal/command prompt.

```
#sudo -s
```

Note: This command is applicable only for Linux machines. For Windows machine administrative permission is necessary.

3. Use below commands on the terminal to establish and verify 'adb' connection.

```
#adb kill-server  
#adb start-server  
#adb devices
```

If the connection is successful, the device id is displayed on the terminal.

4. Run the command below to install the Sensor Hub apk to the Intrinsic Dragon Board.

```
#cd Lightning_Demos_Drop_WITH_APK_INSTALL/Sensor_Hub_Demo_Quick_Start  
/Android_Application
```

Note: This step should be performed only if not currently in the

Lightning_Demos_Drop_WITH_APK_INSTALL/Sensor_Hub_Demo_Quick_start/Android_Application/ folder

```
#adb install Sensor_Hub_Demo.apk
```

Demo Procedure

To execute the demo:

1. Restart Intrinsic Dragon Board by removing and re-plugging in the power supply, with the Sensor Fusion Board connected to it.

When connecting the Sensor Fusion Board to Intrinsic Dragon Board, make sure that jumper J20 on the Sensor Fusion Board is in DRG mode.

2. Wait for Android boot sequence to complete and the home screen to appear.
3. Unlock the screen. Go to the Android application menu and open **Sensor_Hub_LP3.5k_Intrinsic**.
4. Wait for the Processor Configuration to be completed. This is indicated by the lighting of the D3 LED on the Sensor Fusion board.
5. The sensor data is displayed on the Sensor_Hub_LP3.5k_Intrinsic application.

Sensor_Hub_LP3.5k_Intrinsyc Application Features

The Sensor_Hub_LP3.5k_Intrinsyc application provides the following features:

- Temperature and pressure data gives the atmosphere pressure in kPa and room temperature in degree Celcius.
- Compass image points to the magnetic north w.r.t the Sensor Fusion Board.
- Light sensor progress bar indicates the intensity of light form 0 – 4000 lux.
- Accelerometer GUI indicates acceleration in x,y and z direction. The dots indicate the direction and acceleration.
- Gyroscope GUI shows the graphical meter to display the angular rate in x,y and z direction.
- Humidity data gives humidity of the environment in %RH(Relative Humidity). Ambient RGB GUI indicates Red, Green, Blue light values.

Figure 5 shows the Sensor_Hub_LP3.5k_Intrinsyc application interface.

Figure 5. Sensor_Hub_LP3.5k_Intrinsyc Application Interface



Troubleshooting

If the Android application does not respond, perform the following procedure:

1. Close the Sensor_Hub_LP3.5k_intrinsyc process running in background.

In the Android menu, go to

Settings > Applications > Manage Applications > Sensor_Hub_LP3.5k_intrinsyc Force Stop

2. Restart the Intrinsyc Dragon Board.
3. Open the Sensor_Hub application from Android menu and application is ready to receive all sensor's data.
4. If the android application crashes while being opened, it means that the library file has not been copied.

Run the command below to install the Sensor Hub apk to the Intrinsyc Dragon Board.

```
#cd Lightning_Demos_Drop_WITH_APK_INSTALL/Sensor_Hub_Demo_Quick_Start  
/Android_Appllication
```

Note: This step should be performed only if not currently in the

Lightning_Demos_Drop_WITH_APK_INSTALL/Sensor_Hub_Demo_Quick_start/Android_Appllication/ folder

```
#adb install Sensor_Hub_Demo.apk
```

Technical Support Assistance

e-mail: techsupport@latticesemi.com

Internet: www.latticesemi.com

Revision History

Date	Version	Change Summary
January 2014	01.0	Initial release.

© 2014 Lattice Semiconductor Corp. All Lattice trademarks, registered trademarks, patents, and disclaimers are as listed at www.latticesemi.com/legal. All other brand or product names are trademarks or registered trademarks of their respective holders. The specifications and information herein are subject to change without notice.

Appendix A. Sensor Fusion Board Schematic Diagrams

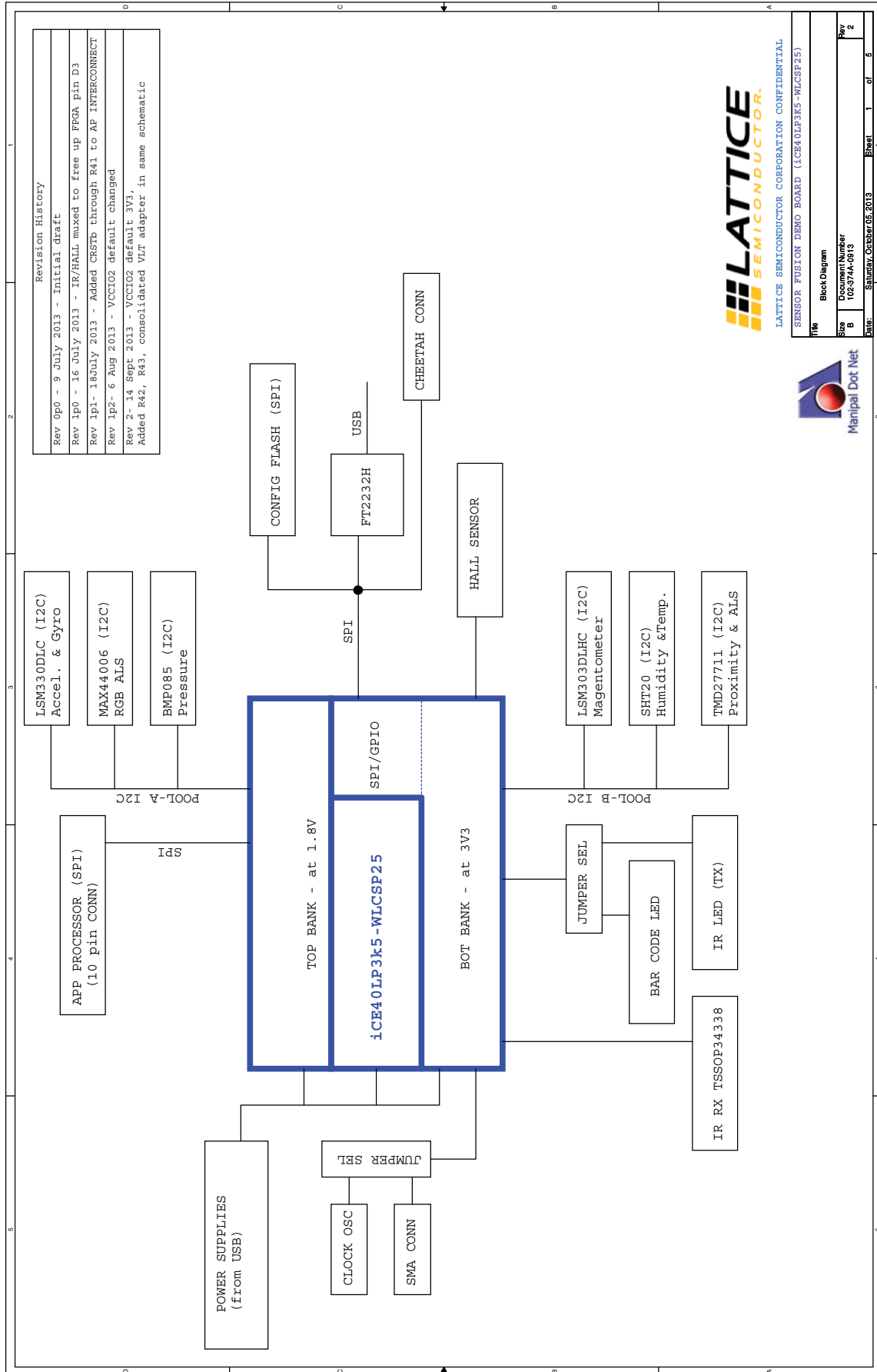

Revision History	
Rev 0p0	9 July 2013 - Initial draft
Rev 1p0	16 July 2013 - IR/HALL mixed to free up FPGA pin D3
Rev 1p1	18 July 2013 - Added CRSTB through R41 to AP INTERCONNECT
Rev 1p2	6 Aug 2013 - VCCIO2 default changed
Rev 2	14 Sept 2013 - VCCIO2 default 3V3, Added R42, R43, consolidated VIF adapter in same schematic



LATTICE SEMICONDUCTOR CORPORATION CONFIDENTIAL
 SENSOR FUSION DEMO BOARD (ICE40LP3K5-WLCSP25)



Title		Block Diagram	
Size	B	Document Number	102-SFM-0813
Date:	Saturday, October 05, 2013	Sheet	1 of 5
Page	2		

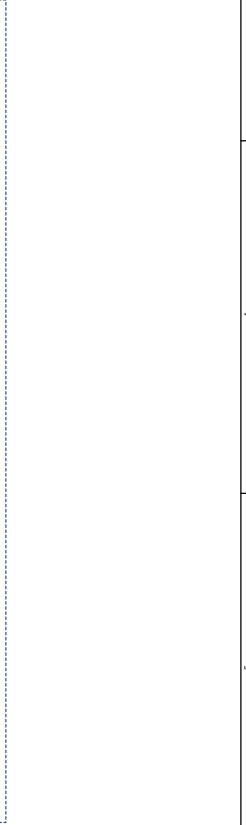
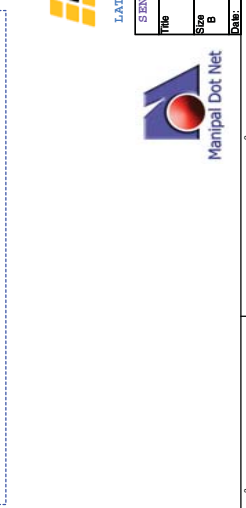
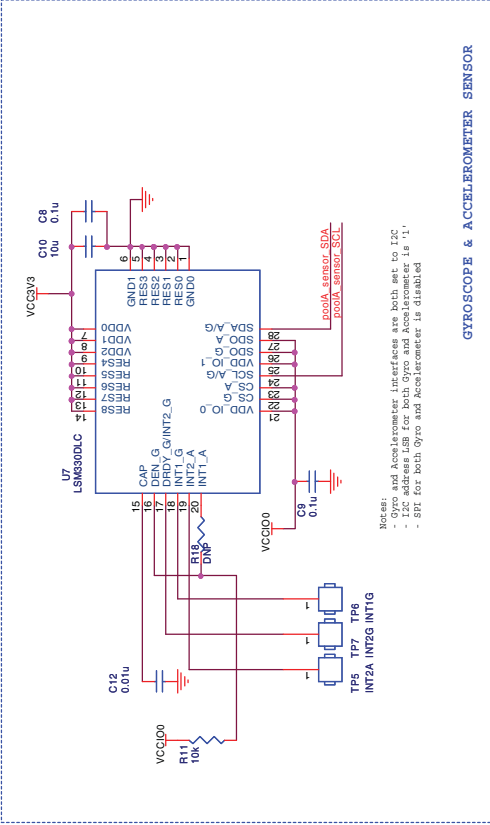
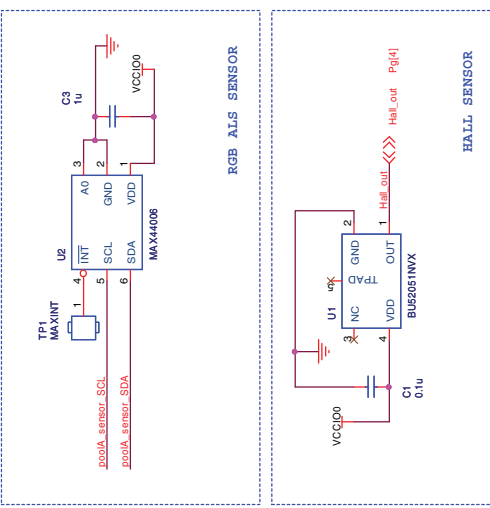
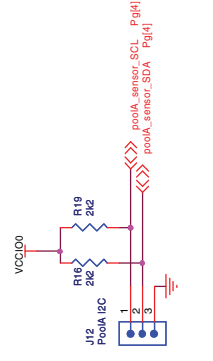
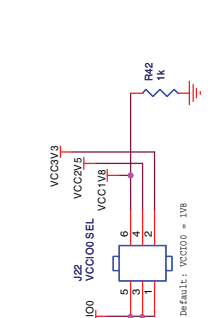
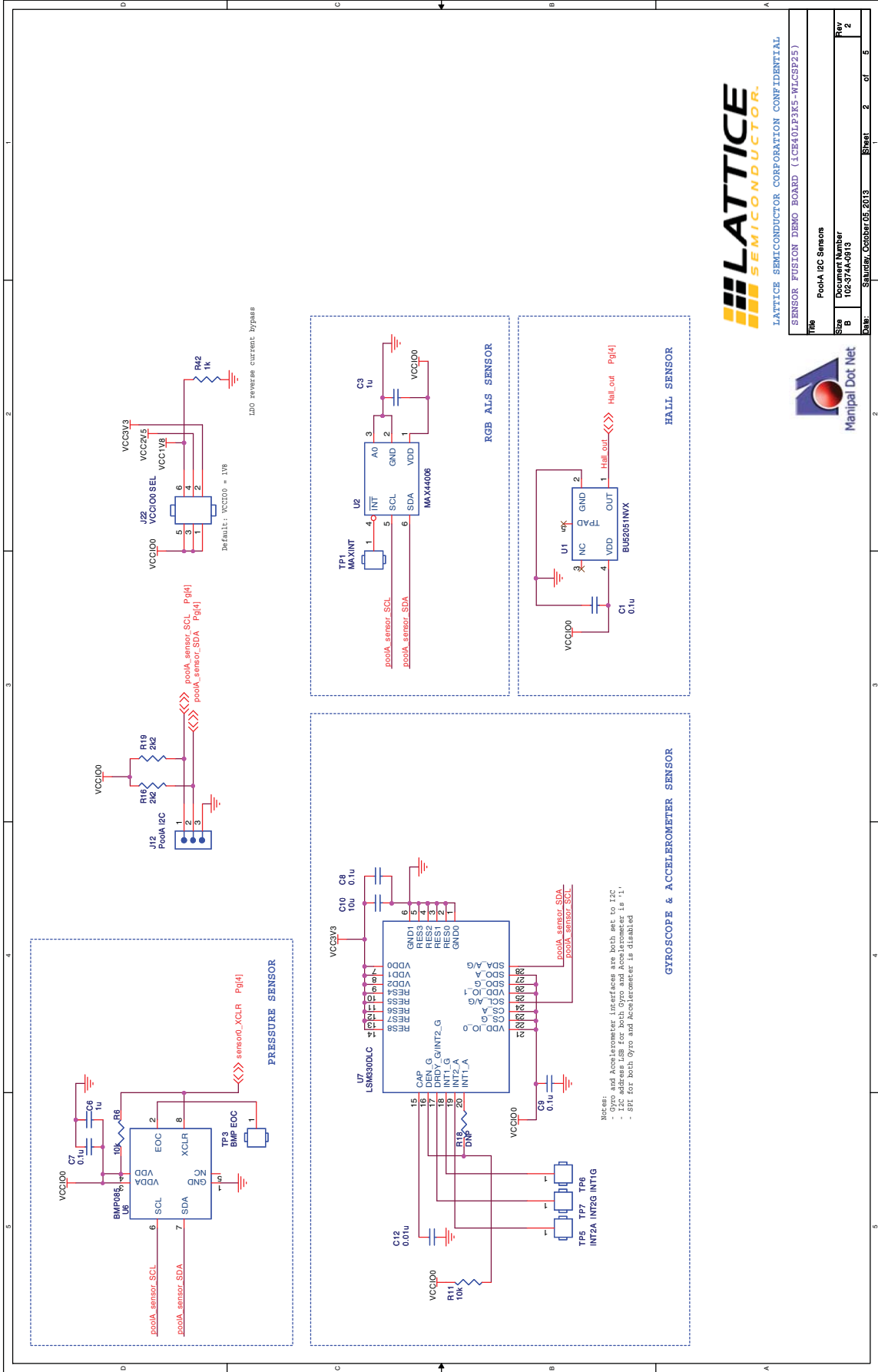

LATTICE SEMICONDUCTOR CORPORATION CONFIDENTIAL
 SENSOR FUSION DEMO BOARD (1CE401P3K5-WLCP25)



File	PoolA I2C Sensors		
Size	B	Document Number	102-3744-0913
Date	Saturday, October 05, 2013	Sheet	2 of 5
Rev	2		

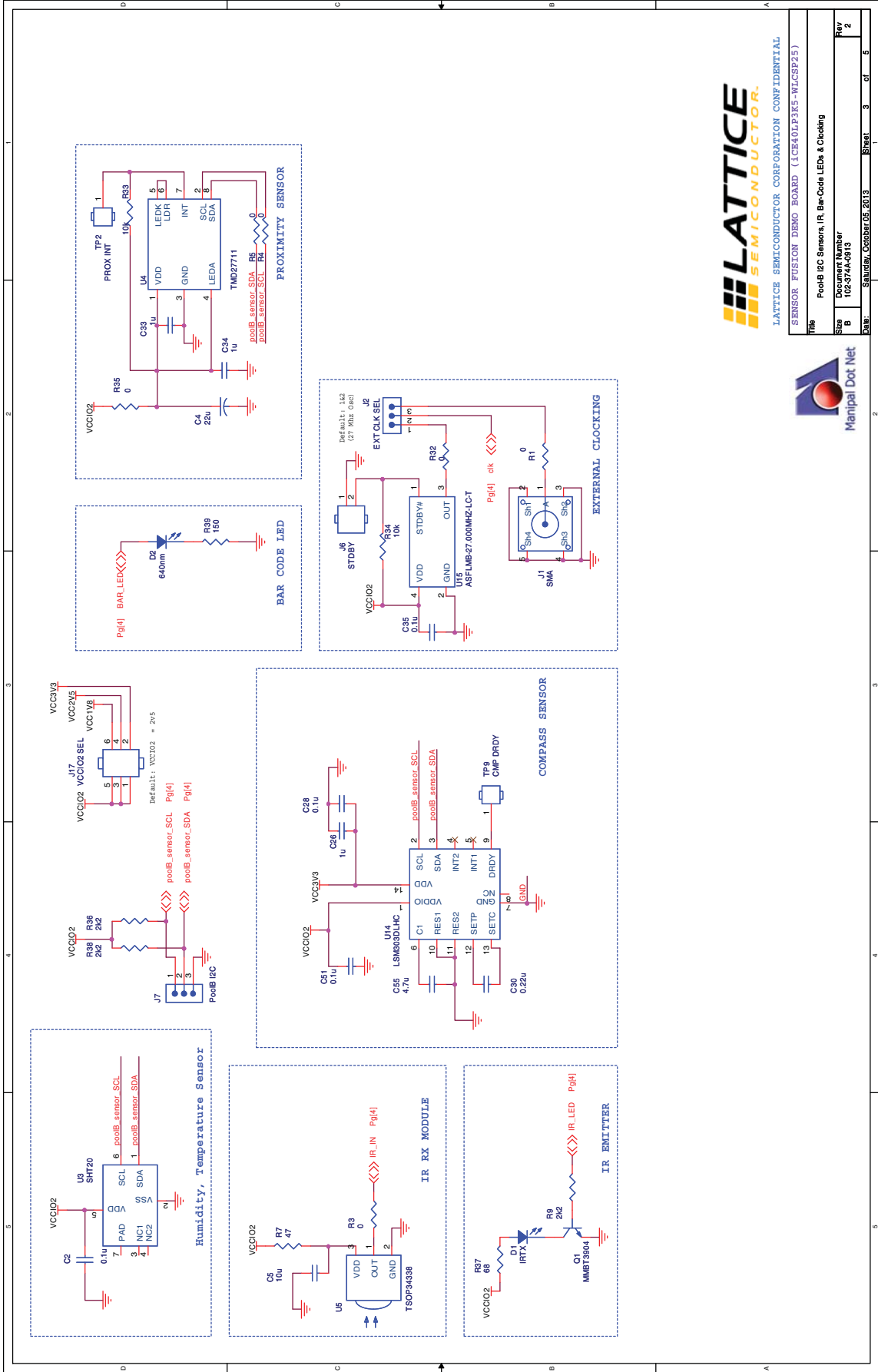

LATTICE SEMICONDUCTOR CORPORATION CONFIDENTIAL
 SENSOR FUSION DEMO BOARD (1CE401F3K5-WLCP25)



File	P00B I2C Sensor, IR, Bar-Code LEDs & Clocking				
Size	B				
Document Number	102-3744-0913				
Date	Saturday, October 05, 2013	Sheet	3	of	5
Rev	2				

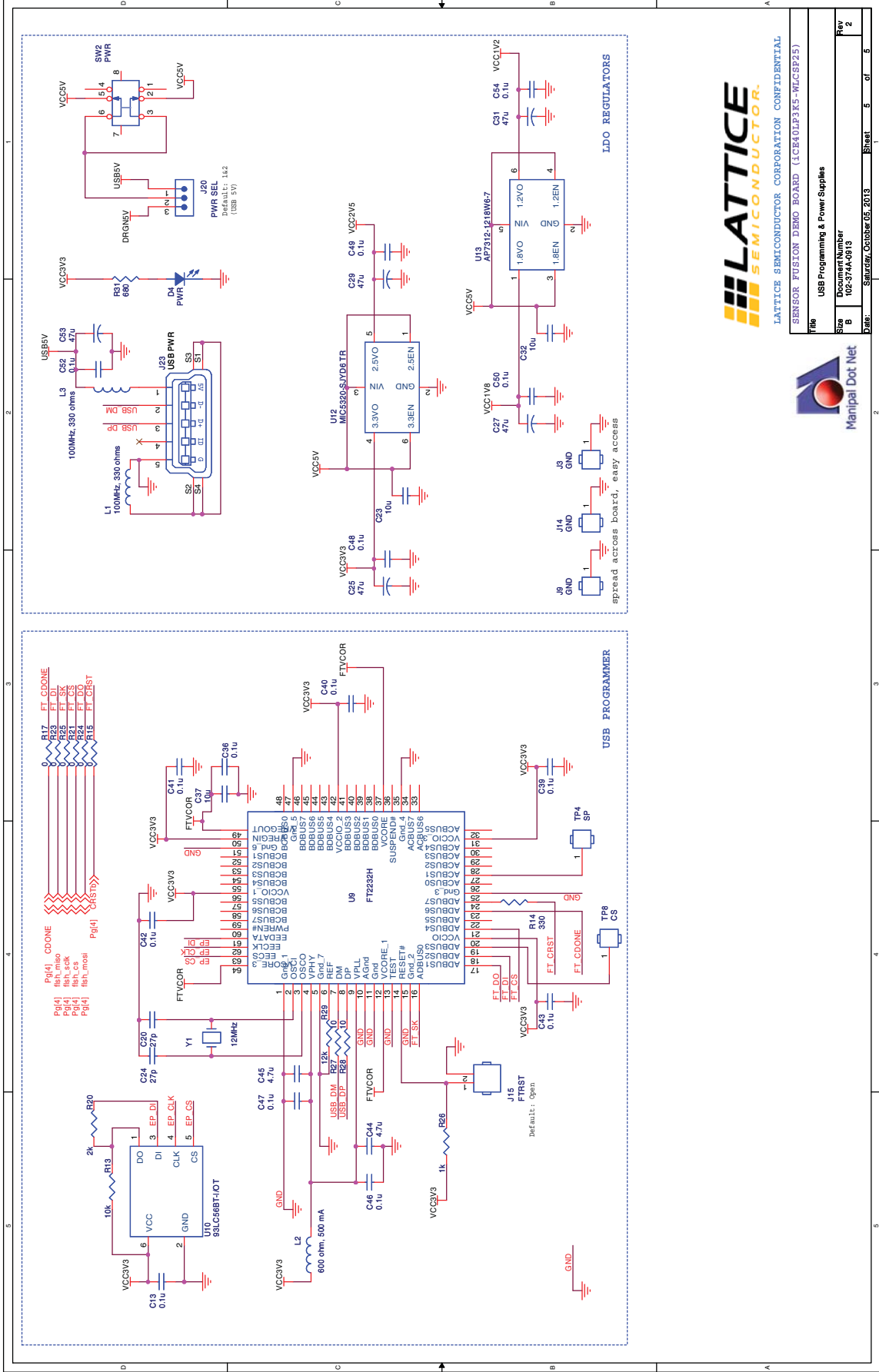

LATTICE SEMICONDUCTOR CORPORATION CONFIDENTIAL
 SENSOR FUSION DEMO BOARD (ICE40LP3K5-WLGS2P5)



File: USB Programming & Power Supplies
 Document Number: 102-3744-0915
 Date: Saturday, October 05, 2013

Sheet 5 of 6

Rev 2

Mouser Electronics

Authorized Distributor

Click to View Pricing, Inventory, Delivery & Lifecycle Information:

Lattice:

[ICE40LM4K-S-EVN](#)